



2009 Strategic Buyer/Public Target Mergers & Acquisitions Deal Points Study

(For Transactions Announced in 2008)

A Project of the Mergers & Acquisitions Market Trends Subcommittee
of the
Mergers & Acquisitions Committee
of the
American Bar Association's Business Law Section

2009 Strategic Buyer/Public Target M&A Deal Points Study **(For Transactions Announced in 2008)**

**A Project of the Mergers & Acquisitions Market Trends Subcommittee
of the Mergers & Acquisitions Committee
of the American Bar Association's Business Law Section**

Subcommittee Chairs

**James R. Griffin, Fulbright & Jaworski L.L.P.
Jessica C. Pearlman, K&L Gates LLP**

Founding Subcommittee Chairs

**Wilson Chu, K&L Gates LLP
Larry Glasgow, Gardere Wynne Sewell, LLP**

Chair, Mergers & Acquisitions Committee

Leigh Walton, Bass Berry & Sims PLC

Special Advisor and Vice Chair, Mergers & Acquisitions Committee

Keith A. Flaum, Dewey & LeBoeuf LLP

Special Advisor and Former Chair, Mergers & Acquisitions Committee

Richard E. Climan, Dewey & LeBoeuf LLP

2009 Strategic Buyer/Public Target Study Working Group

James R. Griffin
Fulbright & Jaworski L.L.P.
Dallas, TX
(Chair)

Luke J. Bergstrom
Latham & Watkins LLP
Menlo Park, CA

George M. Flint III
Parson Behle & Latimer
Salt Lake City, UT

Michael Rave
Day Pitney LLP
Morristown, NJ

Jay E. Bothwick
Wilmer Cutler Pickering Hale and Dorr LLP
Boston, MA

Diane Holt Frankle
DLA Piper LLP (US)
Palo Alto, CA

Jane Ross
Dewey & LeBoeuf LLP
Palo Alto, CA

Maury Bricks
Greenberg Traurig LLP
Atlanta, GA

Michael A. Gold
Baker Botts LLP
Washington, D.C.

Claudia Simon
Paul, Hastings, Janofsky & Walker LLP
San Diego, CA

Michelle Bushore
Latham & Watkins LLP
Menlo Park, CA

John M. Jennings
Nelson Mullins Riley & Scarborough LLP
Greenville, SC

John E. Stoddard, III
Drinker Biddle & Reath LLP
Princeton, NJ

Paul Conneely
Fulbright & Jaworski L.L.P.
Dallas, TX

Jay A. Lefton
Ogilvy Renault LLP
Toronto, Ontario

Lorna J. Telfer
McCarthy Tetrault LLP
Montreal, Quebec

Edward A. Deibert
Howard Rice Nemerovski Canady Falk & Rabin
San Francisco, CA

Hal J. Leibowitz
Wilmer Cutler Pickering Hale and Dorr LLP
Boston, MA

Phillip D. Torrence
Honigman Miller Schwartz and Cohn LLP
Kalamazoo, MI

Erin E. Della Barca
Potter Anderson & Corroon LLP
Wilmington, DE

Michael G. O'Bryan
Morrison & Foerster LLP
San Francisco, CA

Eric Wilensky
Morris, Nichols, Arsht & Tunnell LLP
Wilmington, DE

DISCLAIMERS

The findings presented in this Study do not necessarily reflect the personal views of the Working Group members or the views of their respective firms. In addition, the acquisition agreement provisions that form the basis of this Study are drafted in many different ways and do not always fit precisely into particular "data point" categories. Therefore, Working Group members have had to make various judgment calls regarding, for example, how to categorize the nature or effect of particular provisions. As a result, the conclusions presented in this Study may be subject to important qualifications that are not expressly articulated in this Study. The sample provisions included in this Study are for illustrative purposes only.

2009 Strategic Buyer/Public Target Study Sample Overview

- ◆ This Study analyzes publicly-available acquisition agreements for acquisitions of U.S. publicly-traded targets by publicly-traded and other strategic acquirers for transactions announced in 2008. Acquisition agreements for acquisitions by private equity buyers have not been included among the agreements analyzed for purposes of this Study.
- ◆ Comparative references in this Study to data from “deals in 2005/2006” and “deals in 2007” refer to data in the *2007 Strategic Buyer/Public Target Mergers and Acquisitions Deal Points Study (for transactions announced in 2005/2006)*, and data in the *2008 Strategic Buyer/Public Target Mergers and Acquisitions Deal Points Study (for transactions announced in 2007)*, respectively.
(<http://www.abanet.org/dch/committee.cfm?com=CL560003>).

Transaction Value* Range	# of Deals	Consideration		
		All Cash	All Stock	Mixed
\$100M and over	103**	66%	15%	19%

* Includes target debt at time of signing, if applicable.

** Includes 36 deals structured as negotiated tender offers.

Contents

	Slide
I. Target's Representations and Warranties	7
A. Financial Statements – “Fair Presentation” Representation.....	8
B. “No Undisclosed Liabilities” Representation.	10
C. “Compliance with Law ” Representation.....	12
D. “Full Disclosure ” Representation.....	14
II. Conditions to Closing	16
A. Accuracy of Target's Representations	17
B. Target's “Covenant Compliance”.....	25
C. Buyer's MAC/MAE “Walk Right”.....	27
D. Opinion of Target's Counsel.....	34
E. Retention of Specified Employees of Target	36
F. No Governmental Litigation Challenging the Transaction.....	38
G. No Non-Governmental Litigation Challenging the Transaction.....	40
H. Availability of Financing	42
I. Receipt/Bring Down of Fairness Opinion by Target Advisor.....	44
J. Appraisal Rights	46
III. Deal Protection and Related Provisions	48
A. Target No-Shop/No-Talk; Fiduciary Exception to No-Talk.....	49
B. Go Shop	54
C. Fiduciary Exception to Target Board Recommendation Covenant	56
D. Target Fiduciary (Superior Offer) Termination Right.....	60
E. Buyer “Match Right” Relating to Target Fiduciary (Superior Offer) Termination Right.....	62
F. Target Break-Up Fee Triggers.....	65

Contents

		Slide
IV.	Other Acquisition Agreement Data Points	71
A.	Operating Covenant	72
B.	D&O Insurance	77
C.	Choice of Law	79
D.	No Other Representations/Non-Reliance	81
V.	Remedies	84
A.	Specific Performance	85
B.	Effect of Termination	89
C.	“Willful, Knowing, Intentional” Defined?	92
D.	Express Target Right to Pursue Damages on Behalf of Stockholders	94
E.	Termination Fee Payable by Buyer	96
VI.	Two-Step Cash Transactions (Tender Offer Deals)	100
A.	Structure of Cash Deals	101
B.	Minimum Condition	102
C.	Top-Up Option	105
D.	Conditions Regarding Trading Suspension; Banking Moratorium; War/Terrorism; Limitation on Extension of Credit	109

Target's Representations and Warranties

“Fair Presentation” Representation

(“Fairly Presents” is GAAP Qualified)

“**Financial Statements.** The Target Financial Statements fairly present the financial position of the Target and its consolidated subsidiaries as of the respective dates thereof and the results of operations and cash flows of the Target and its consolidated subsidiaries for the periods covered thereby, **all in accordance with GAAP.**”

(“Fairly Presents” is not GAAP Qualified)

“**Financial Statements.** The Target Financial Statements fairly present the financial position of the Target and its consolidated subsidiaries as of the respective dates thereof and the results of operations and cash flows of the Target and its consolidated subsidiaries for the periods covered thereby. The Target Financial Statements have been prepared in accordance with GAAP applied on a consistent basis throughout the periods covered.”

"Fair Presentation" Representation

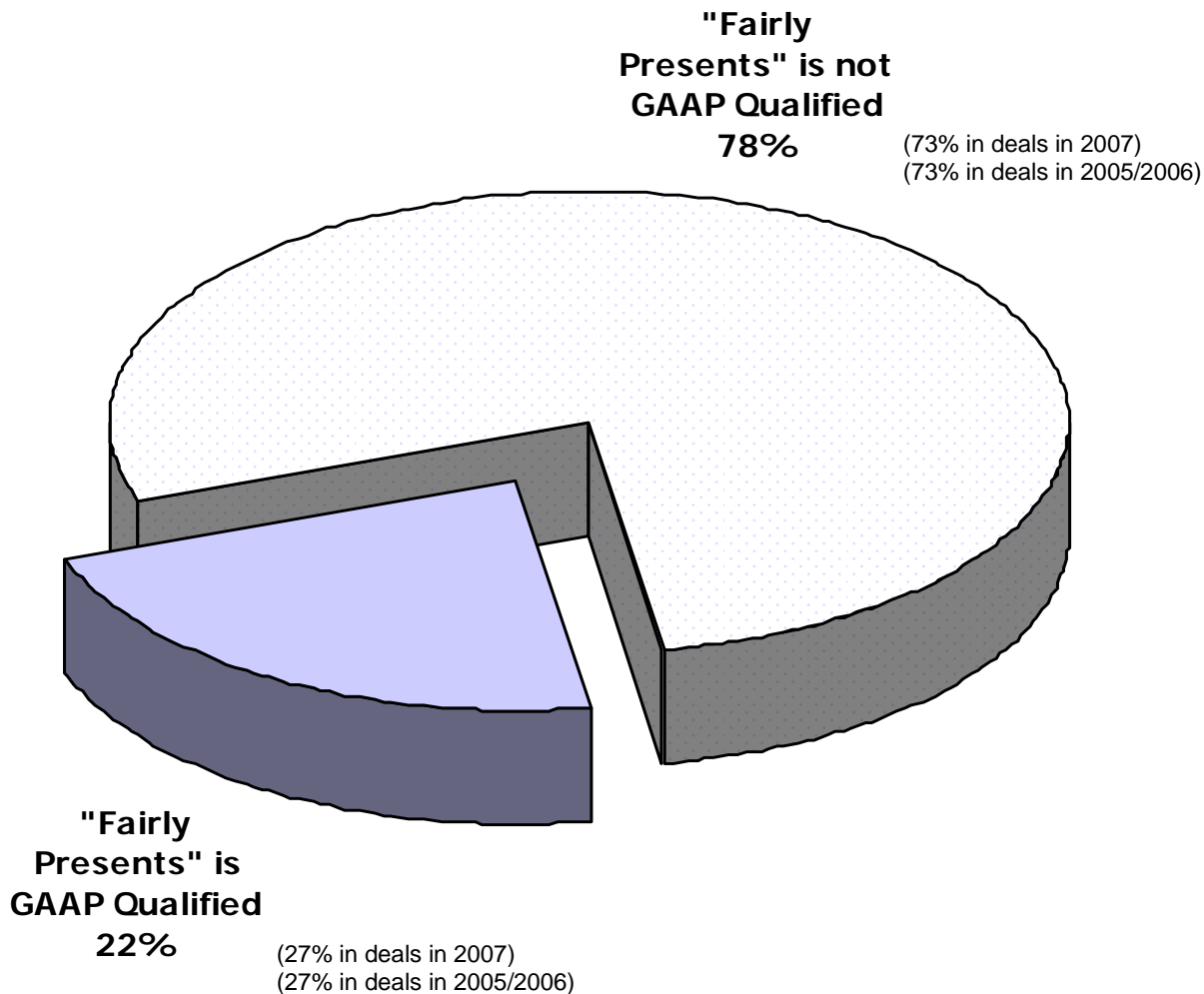

“No Undisclosed Liabilities” Representation

All Liabilities

“No Undisclosed Liabilities. The Target has no **accrued, contingent or other liabilities of any nature, either matured or unmatured,** except for . . .”

GAAP Liabilities

“No Undisclosed Liabilities. The Target has no liabilities **of the type required to be disclosed in the liabilities column of a balance sheet prepared in accordance with GAAP,** except for . . .”

"No Undisclosed Liabilities" Representation

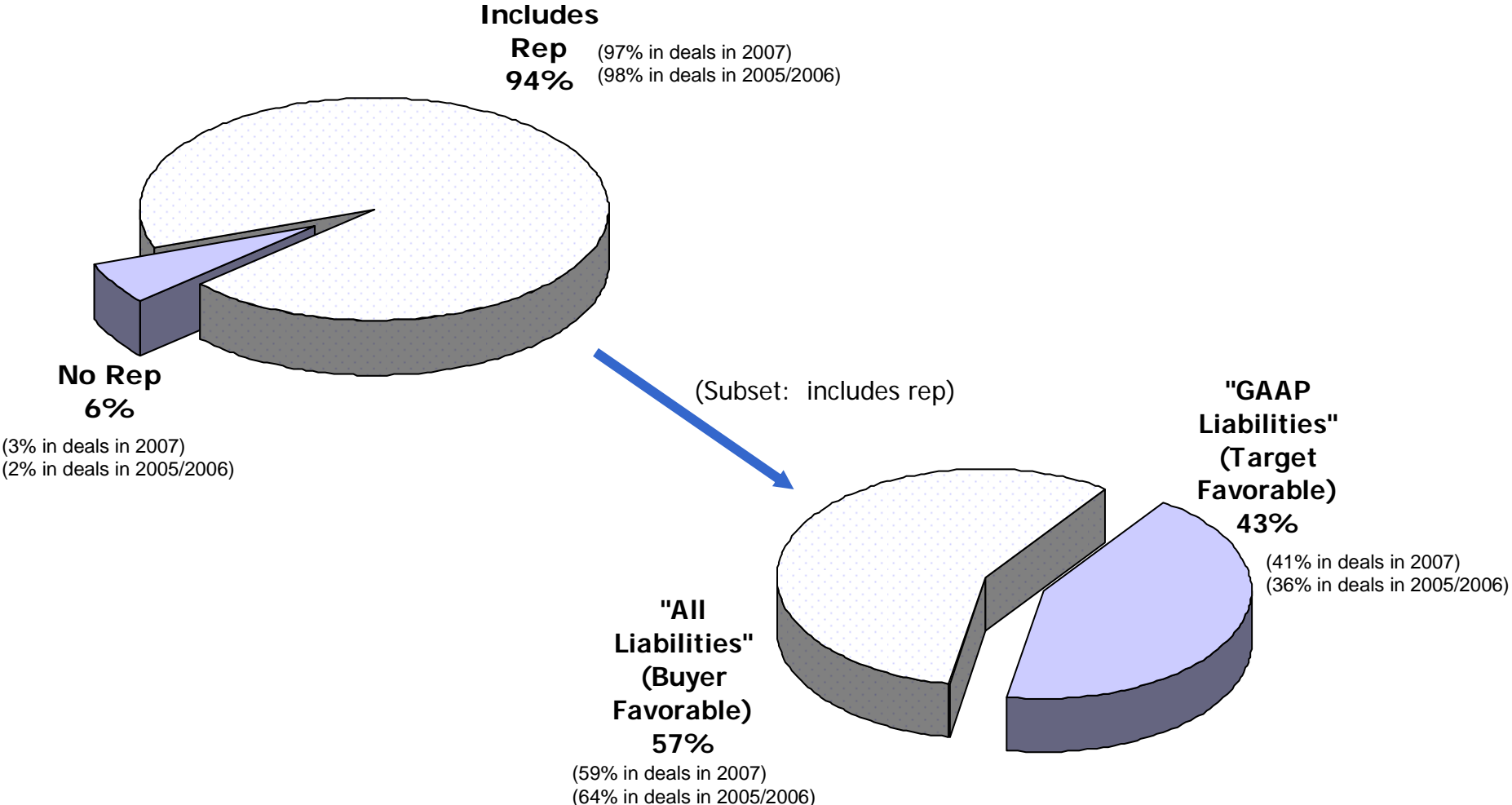

“Compliance with Law” Representation

“No Time Limit” Compliance

“**Compliance with Law.** The Target is, **and at all times has been**, in compliance with all Applicable Law . . .”

“Date Restricted” Compliance

“**Compliance with Law.** Target is, and at all times **since December 31, 2007 has been**, in compliance with all Applicable Law . . .”

Current Compliance

“**Compliance with Law.** Target **is in compliance** with all Applicable Law . . .”

Notice of Violation

“**Compliance with Law.** Target **(i)** is, and at all times has been, in compliance with all Applicable Law **and (ii) has not received [written] notice of any violation of Applicable Law . . .**”

"Compliance with Law" Representation

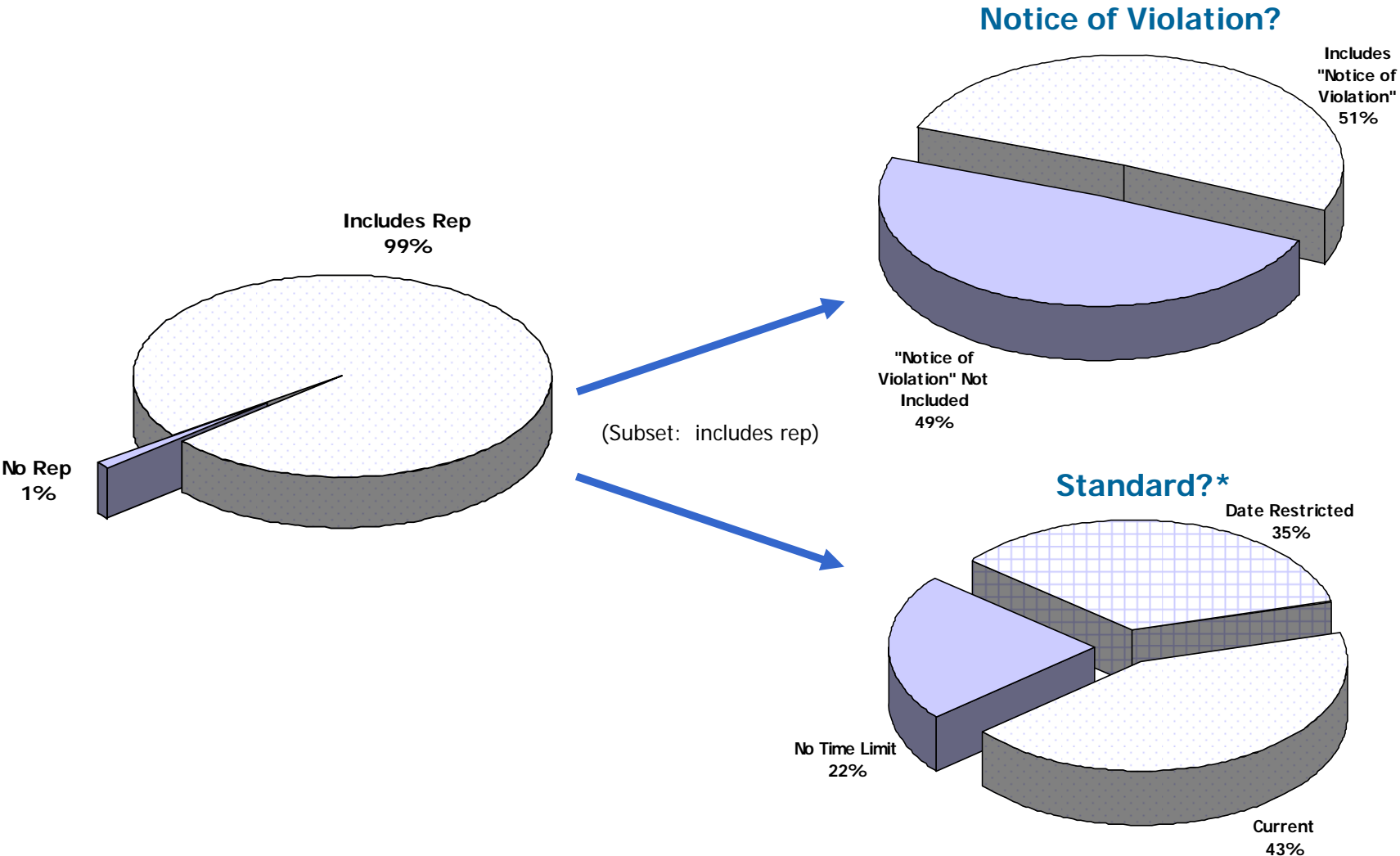

* A number of transactions had more stringent standards for certain aspects of the target's business or where compliance with law with respect to a specific representation had been addressed by a subject-specific representation (e.g. environmental, intellectual property, etc.)

“Full Disclosure” Representation

“Full Disclosure. [To the knowledge of the Target,]
No representation or warranty made by the Target in this Agreement contains any untrue statement of a material fact or omits to state a material fact necessary to make any such representation or warranty, in light of the circumstances in which it was made, not misleading.”

"Full Disclosure" Representation

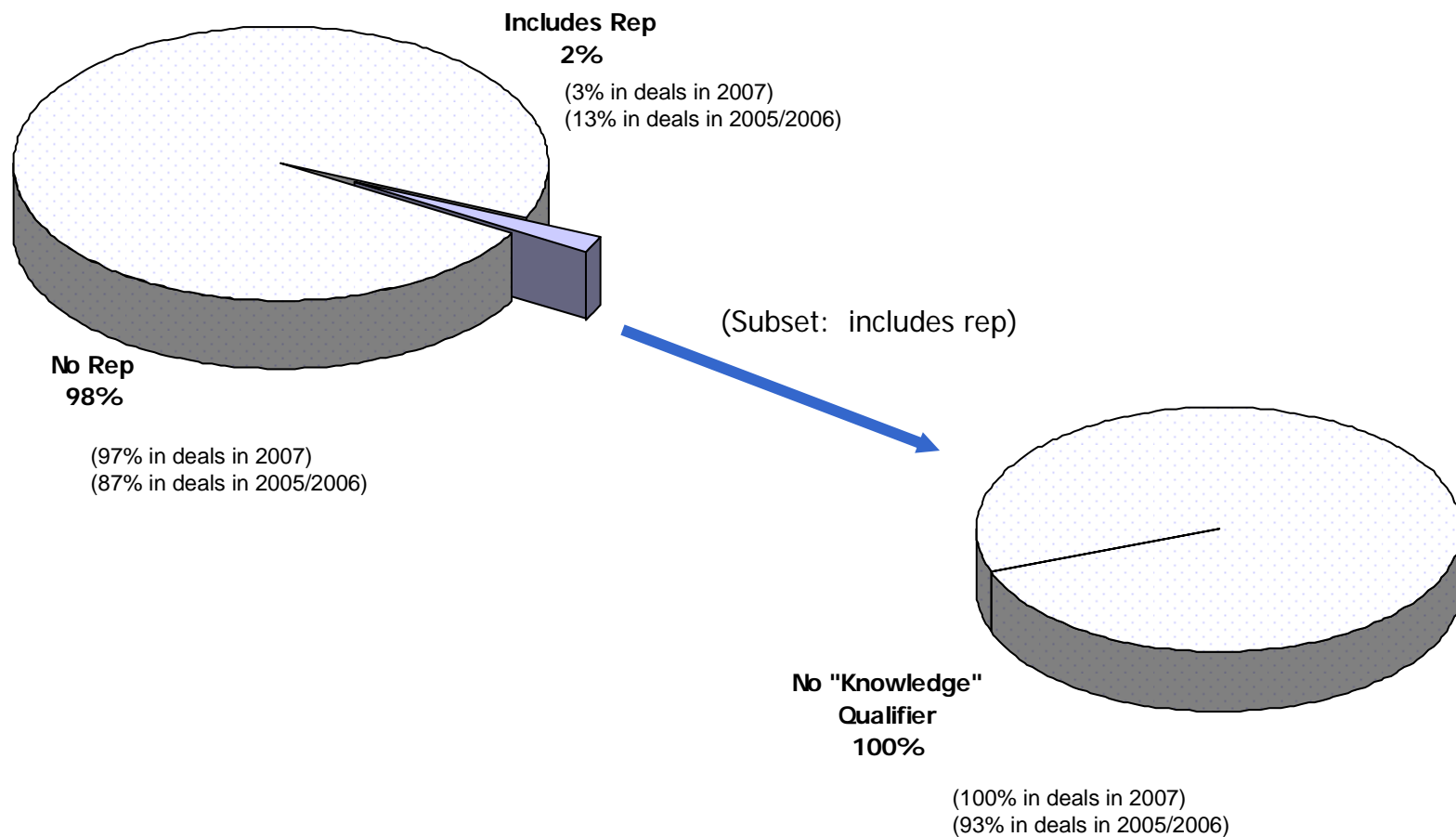

Conditions to Closing

Accuracy of Target's Representations - When Must They Be Accurate? (Two Points in Time: At Signing and At Closing)

“**Accuracy of Representations and Warranties.** Each of the representations and warranties made by the Target in this Agreement shall have been accurate in all respects as of the **date of this Agreement**, and shall be accurate in all respects as of the **Closing Date** as if made on the Closing Date.”

Accuracy of Target's Representations – When Must They Be Accurate?

“When Made”* (i.e., at Signing)

Includes “When Made” Requirement 77% (79% in deals in 2007) (81% in deals in 2005/2006)

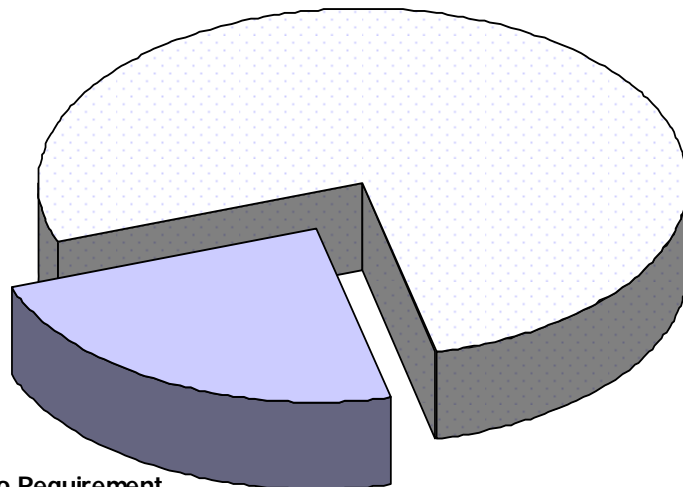

No Requirement
23%

(21% in deals in 2007)
(19% in deals in 2005/2006)

“Bring Down”** (i.e., at Closing)

Includes “Bring Down” Requirement 100% (100% in deals in 2007 and 2005/2006)

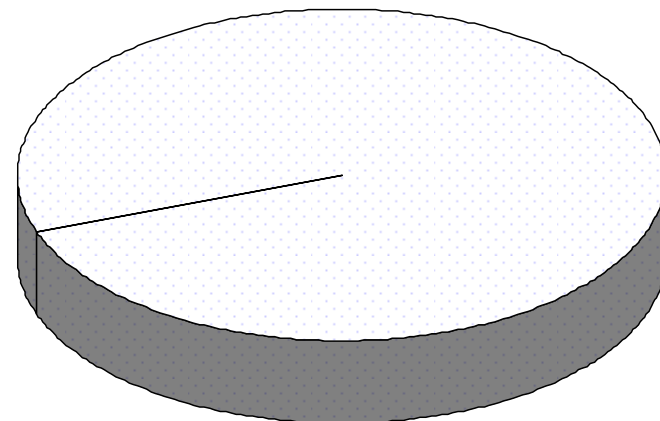

* Includes deals with only certain representations containing a “when made” component.

** Includes deals with both “when made” and “bring down” requirement and deals solely with a “bring down” requirement.

Accuracy of Target's Representations – How Accurate Must They Be? ("Accurate In All Material Respects")

"Accuracy of Representations and Warranties. Each of the representations and warranties made by the Target in this Agreement shall have been accurate **in all material respects** as of the Closing Date as if made on the Closing Date."

Accuracy of Target's Representations – How Accurate Must They Be? (MAC/MAE Qualification)

“Accuracy of Representations and Warranties. Each of the representations and warranties made by the Target in this Agreement shall have been accurate in all respects as of the Closing Date as if made on the Closing Date, **except for inaccuracies of representations or warranties the circumstances giving rise to which, individually or in the aggregate, do not constitute and could not reasonably be expected to result in a Material Adverse Effect.**”

Accuracy of Target's Representations – How Accurate Must They Be? ("Double Materiality" Carveout)

“Accuracy of Representations and Warranties. Each of the representations and warranties made by the Target in this Agreement shall have been accurate in all respects as of the Closing Date as if made on the Closing Date, except for inaccuracies of representations or warranties the circumstances giving rise to which, individually or in the aggregate, do not constitute and could not reasonably be expected to result in a Material Adverse Effect (it being understood that, **for purposes of determining the accuracy of such representations and warranties, all "Material Adverse Effect" qualifications and other materiality qualifications contained in such representations and warranties shall be disregarded.**”

Accuracy of Target's Representations – How Accurate Must They Be? (Materiality Qualifier In “Bring Down” Component)*

Materiality Standard**

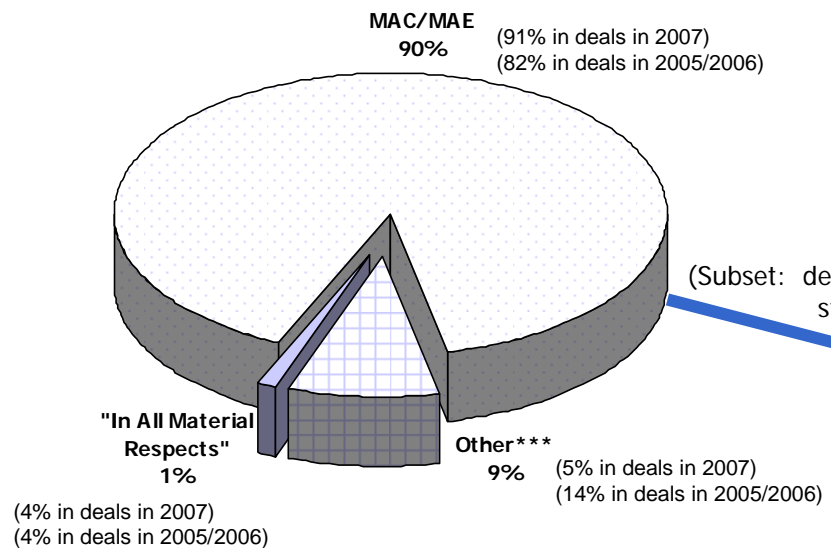

(Subset: deals with MAC/MAE standard)

“Double Materiality” Carveout

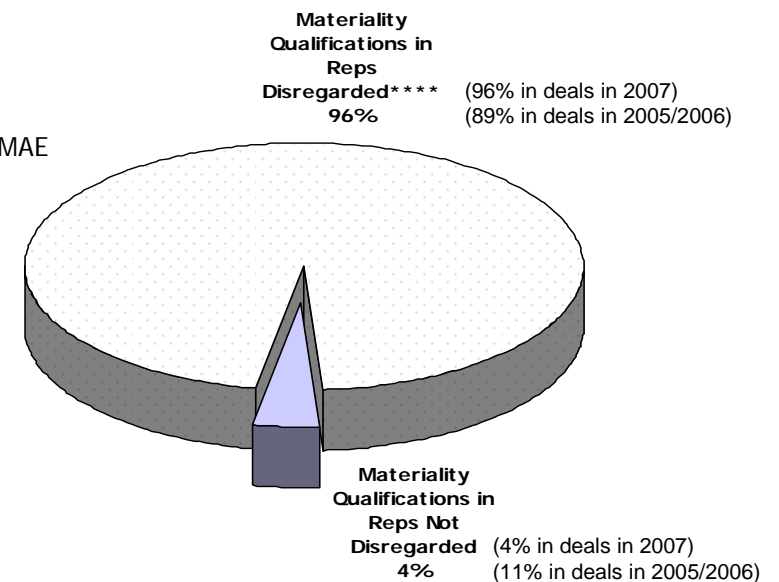

- * The statistics for materiality qualifiers in the “when made” component were substantially similar to the “bring down” statistics.
- ** Many deals included separate (and different) materiality standards for the capitalization and certain other representations. See slide 24 for capitalization representation standards.
- *** “Other” includes “in all respects if qualified by materiality and in all material respects if not so qualified.”
- **** A number of deals carved out the “No Material Adverse Change” or similar representation from the “disregarded materiality” concept.

Accuracy of Target's Representations How Accurate Must They Be? MAE Qualifier With Capitalization Carve Out

“Accuracy of Representations and Warranties. (i) The representation and warranty set forth in Section 3.3 (Capitalization) shall have been accurate [in all respects/in all respects other than de minimis inaccuracies/in all material respects] as of the Closing Date as if made on the Closing Date, and (ii) each of the other representations and warranties made by the Target in this Agreement shall have been accurate in all respects as of the Closing Date as if made on the Closing Date, except for inaccuracies of representations or warranties the circumstances giving rise to which, individually or in the aggregate, do not constitute and could not reasonably be expected to result in a Material Adverse Effect. . .”

Accuracy of Target's Representations

How Accurate Must They Be?

MAE Qualifier With Capitalization Carve Out*

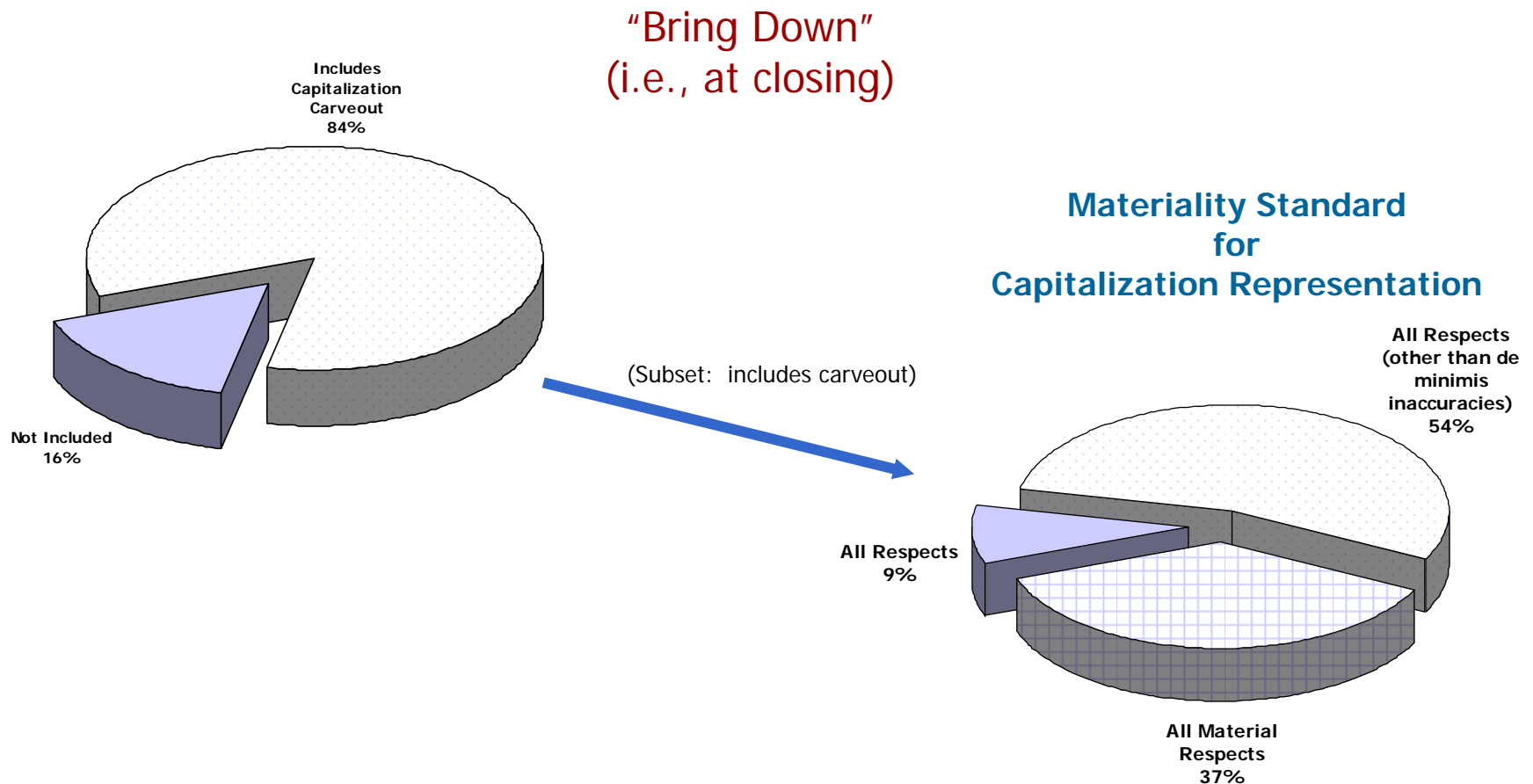

* The statistics with respect to the capitalization carve out in the "when made" component were substantially similar to the bring down" statistics.

Target's "Covenant Compliance"

Compliance with "each" covenant

"Performance of Obligations of the Company. Target shall have performed [in all material respects/all respects] **each** of its obligations required to be performed by it under this Agreement."

Other Formulations

"Performance of Obligations of the Company. Target shall have performed **its** obligations required to be performed by it under this Agreement [in all material respects/all respects]."

"Performance of Obligations of the Company. Target shall have performed **all** of the obligations required to be performed by it under this Agreement [in all material respects/all respects.]"

Target's "Covenant Compliance"

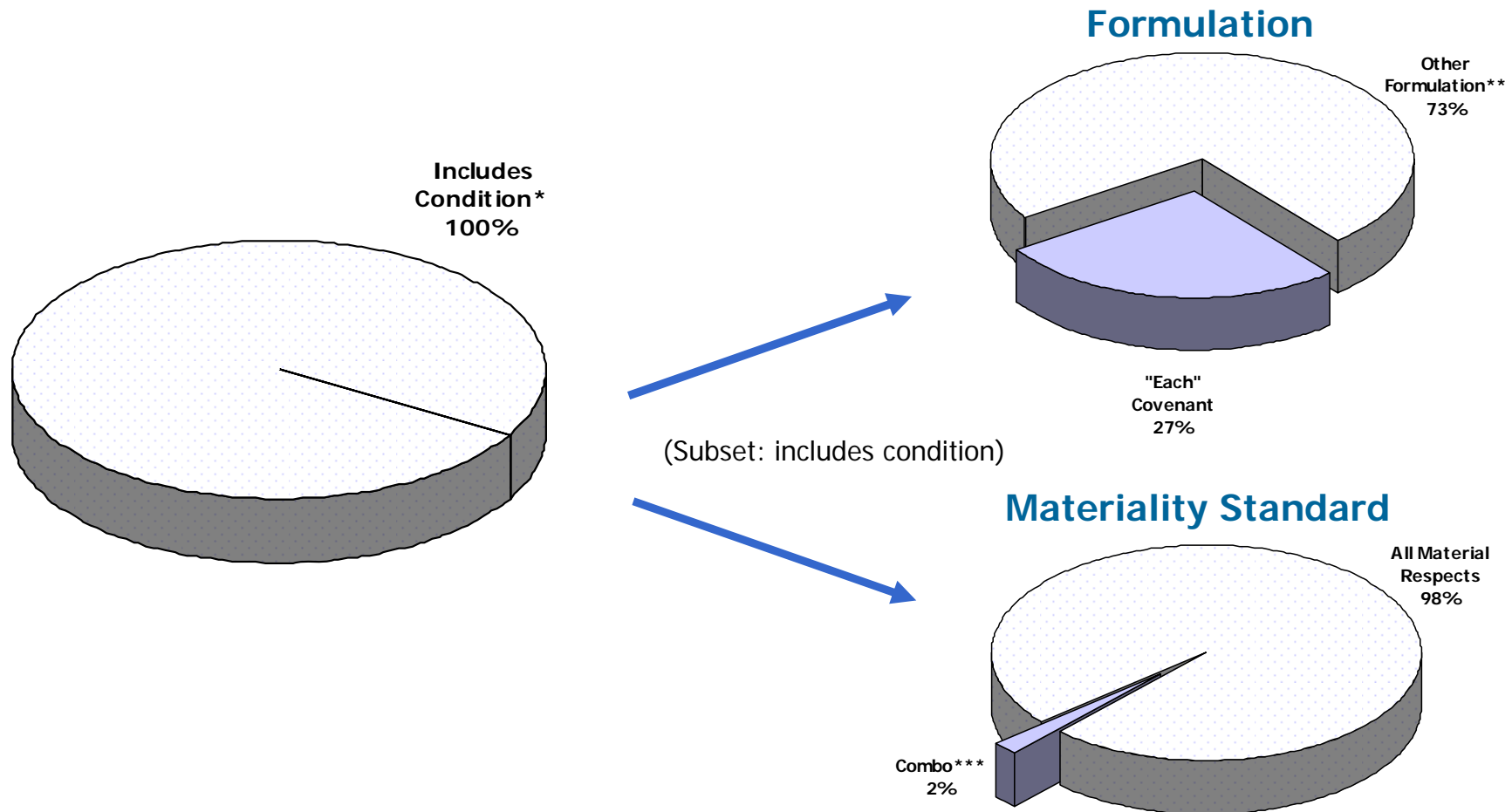

- * Some transactions based the closing condition on the target's compliance with "material covenants" rather than covenants in general.
- ** Unless the provision specifically stated each covenant must be complied with, the data was categorized in the "other" category. Accordingly, some formulations included in "other" category could, in some instances, be construed as requiring compliance with "each" covenant.
- *** Combo" category represents a compliance condition in which certain covenants required compliance "in all respects" and other covenants required compliance in "all material respects." Two transactions provided that materiality qualifiers in the covenants be disregarded for purposes of testing the covenant closing condition.

Buyer's MAC/MAE "Walk Right"

"No Material Adverse Change. Since the date of this Agreement, there has not been any material adverse change in the business, financial condition or results of operations of the Target and its Subsidiaries taken as a whole."

Buyer's MAC/MAE "Walk Right"*

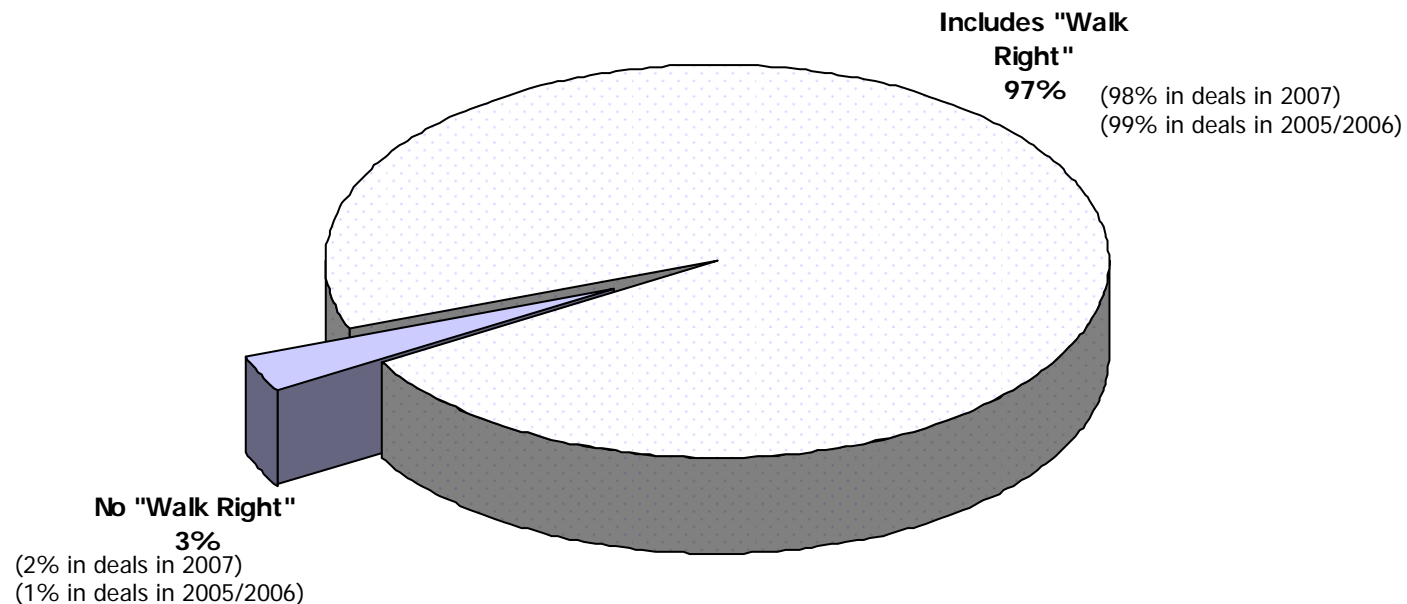

* MAC/MAE "walk right" includes closing condition, specific termination right in termination section and "back door" MAC/MAE (i.e., MAC/MAE closing condition or termination right through bring down of MAC/MAE representation).

Buyer's MAC/MAE "Walk Right" (Prospects)

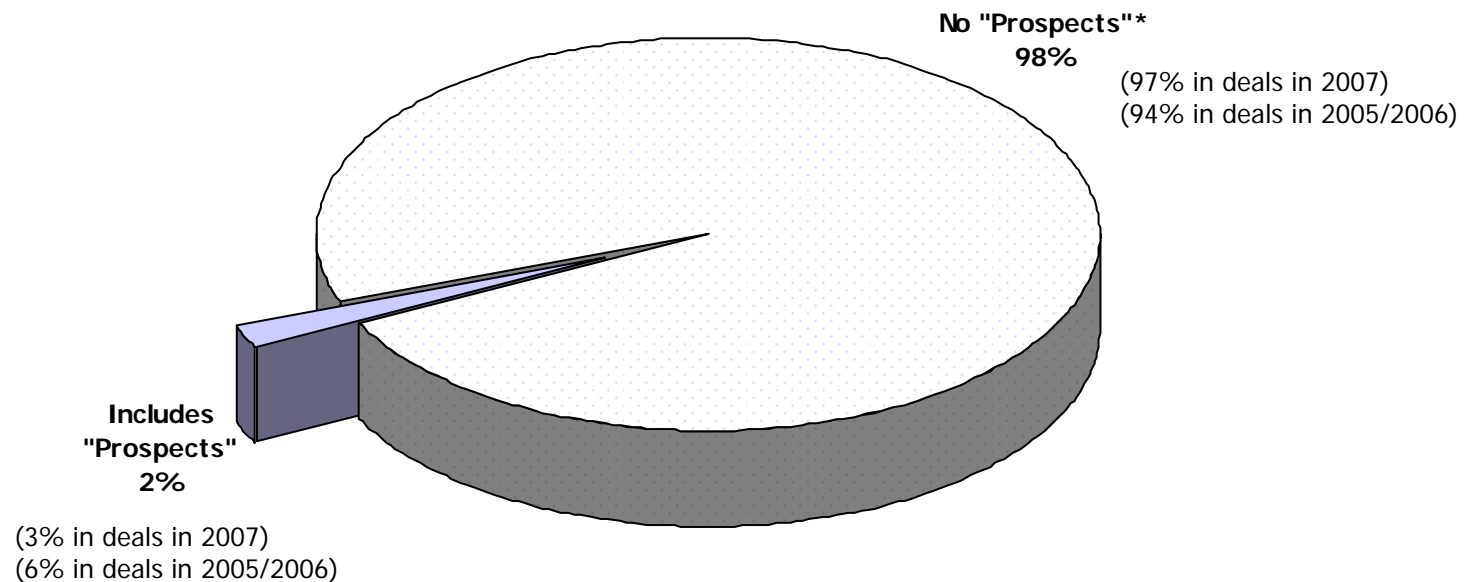

* A substantial number of the acquisition agreements that did not include the word "prospects" in the MAC/MAE clause did include other forward-looking language in that clause, such as "events that could/would reasonably be expected to result in a MAC/MAE."

MAC/MAE Carveouts

"MATERIAL ADVERSE CHANGE/EFFECT" means, when used in connection with the Target, any change, event, violation, inaccuracy, circumstance or effect that is materially adverse to the business, financial condition or results of operations of the Target and its Subsidiaries taken as a whole, **other than as a result of: (i) changes adversely affecting the United States economy (so long as the Target is not disproportionately affected thereby); (ii) changes adversely affecting the industry in which the Target operates (so long as the Target is not disproportionately affected thereby); (iii) the announcement or pendency of the transactions contemplated by this Agreement; (iv) the failure to meet analyst projections, in and of itself; (v) changes in laws; (vi) changes in accounting principles; or (vii) acts of war or terrorism.**

MAC/MAE Carveouts (General Economy)

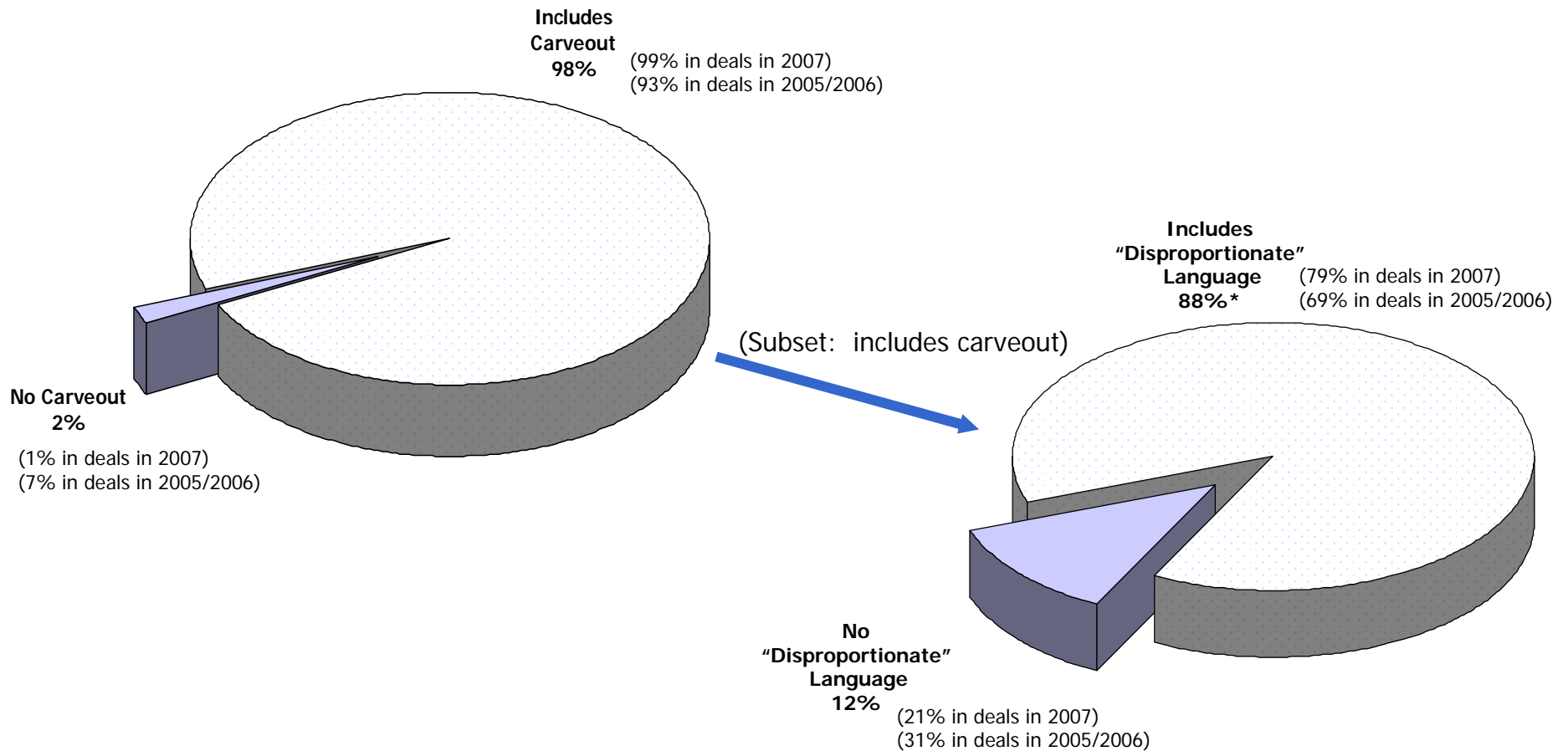

* Approximately 47% of the transactions in 2008 that required a "disproportionate" impact to be taken into account required such impact to be "material," "substantial" or similar language.

MAC/MAE Carveouts (Industry)

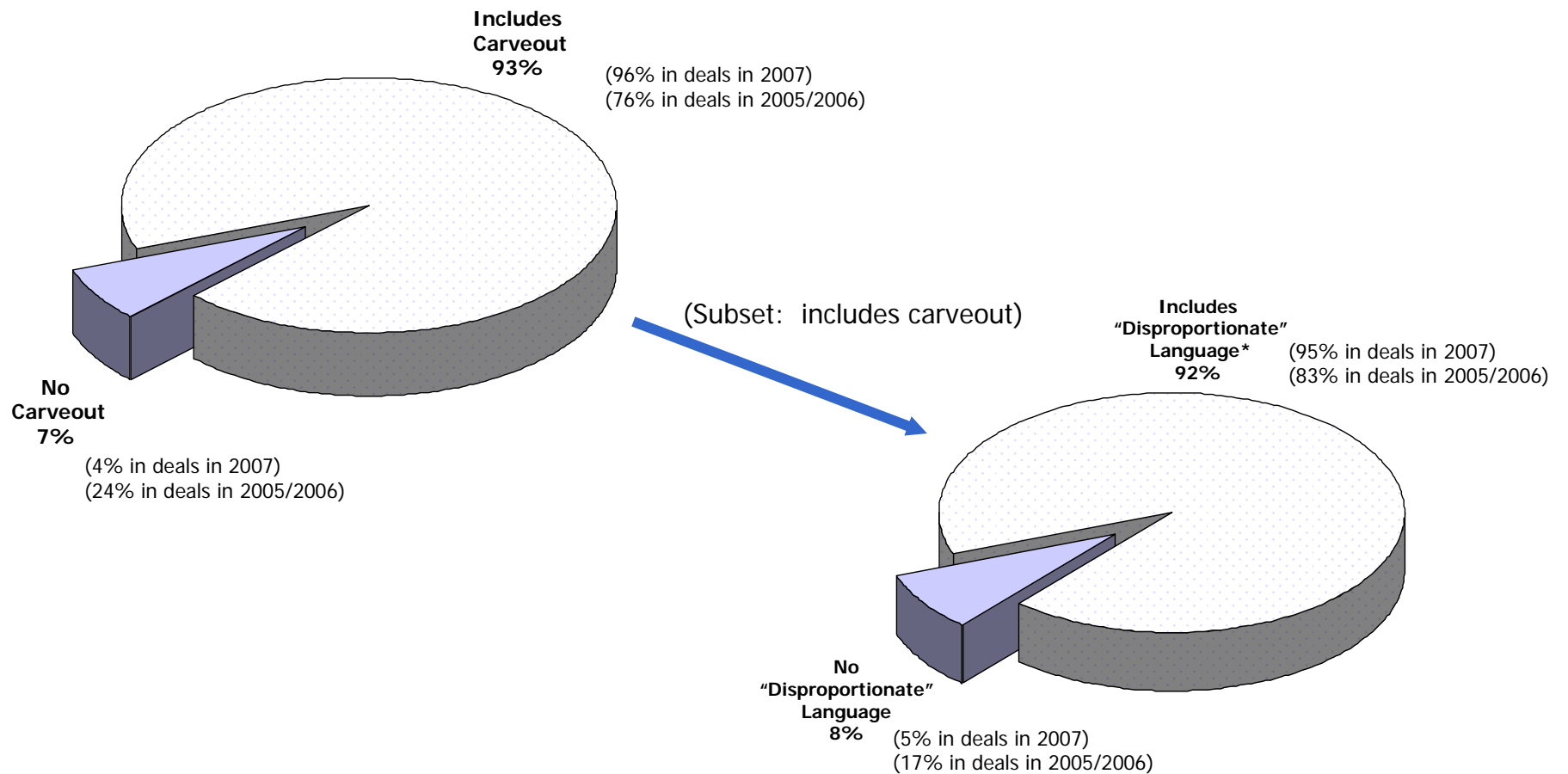

* Approximately 53% of the transactions in 2008 requiring a “disproportionate” impact to be taken into account required such impact to be “material,” “substantial” or similar language.

Other Popular MAC/MAE Carveouts

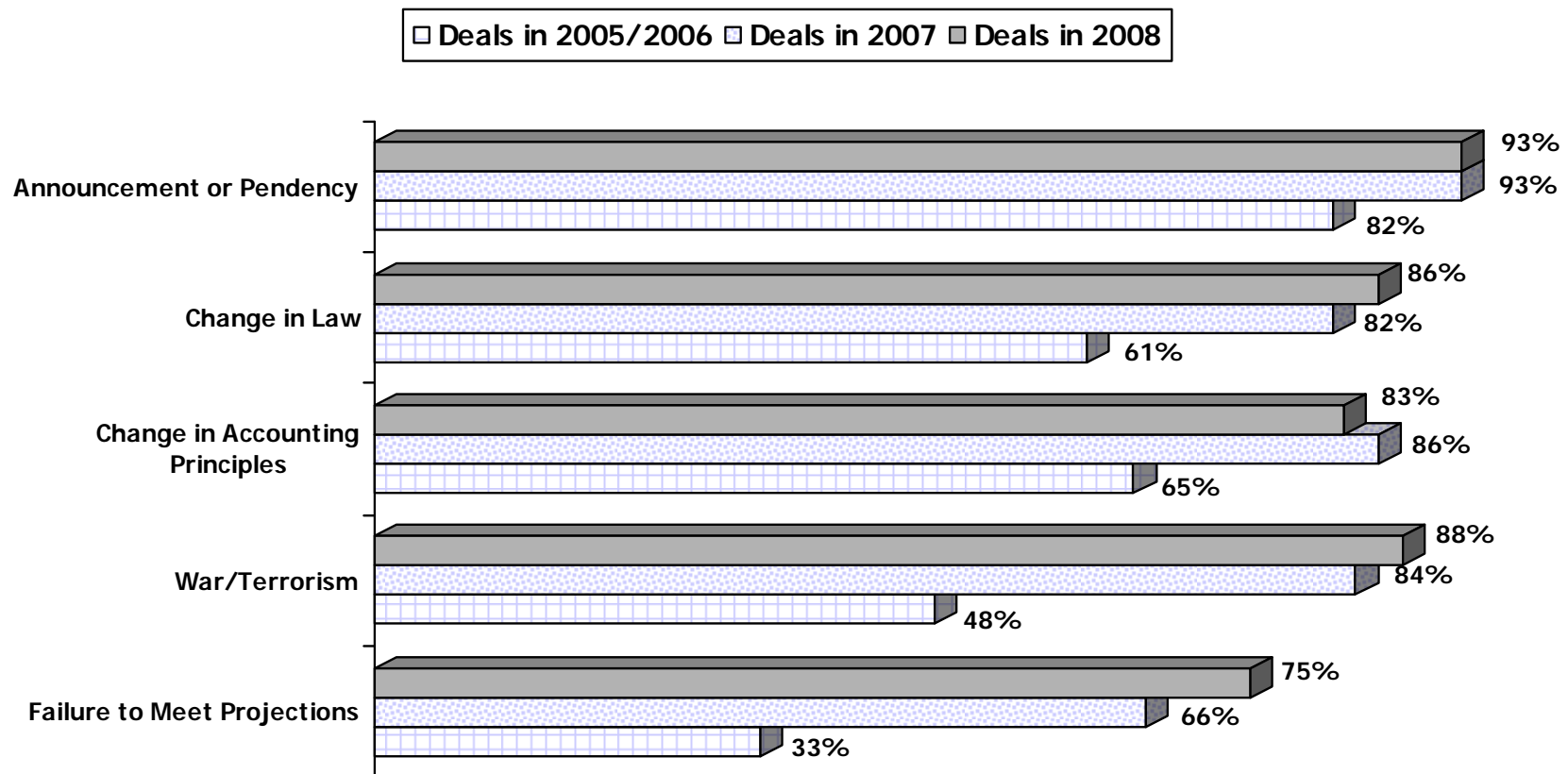

Opinion of Target's Counsel (Not Including Tax Opinion)

“Agreements and Documents. The Buyer shall have received the following agreements and documents, each of which shall be in full force and effect: . . . (___) a legal opinion of [counsel to the Target], substantially in the form of Exhibit ___;”

Opinion of Target's Counsel (Not Including Tax Opinion)

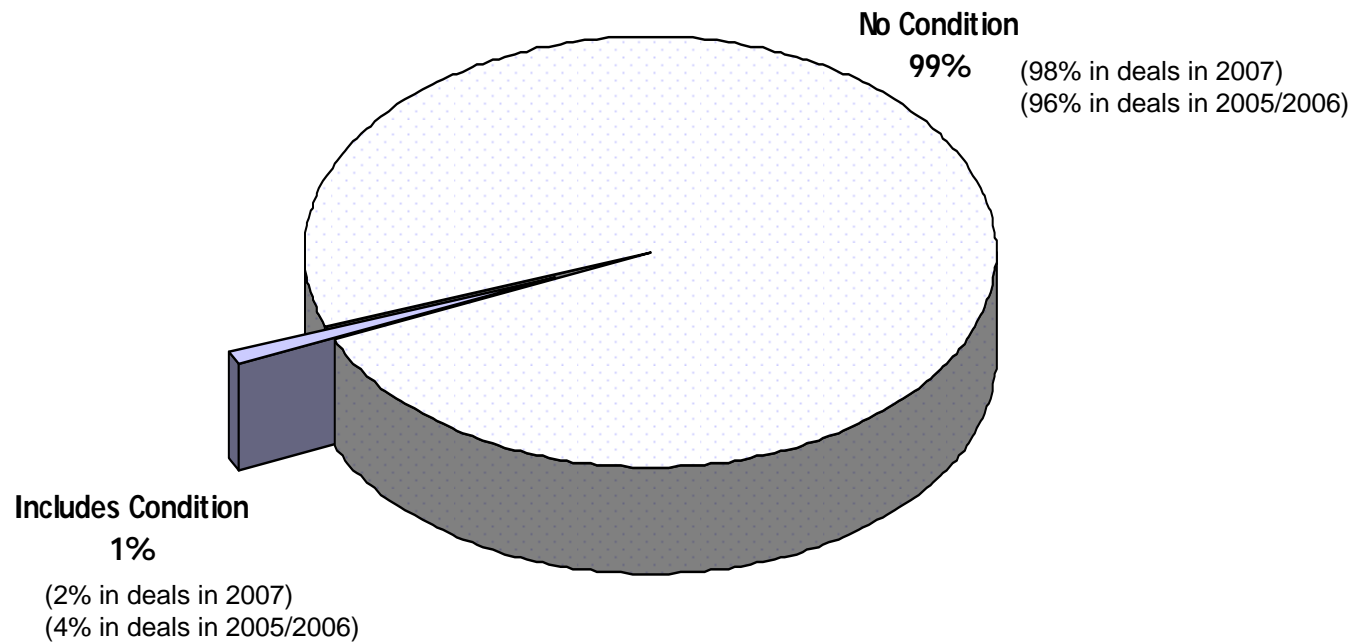

Retention of Specified Employees of Target

“Employees. None of the individuals identified on Schedule 6.7(a) shall have ceased to be employed by the Target, or shall have expressed an intention to terminate his or her employment with the Target or to decline to accept employment with the Buyer; and not more than [__]% of the individuals identified on Schedule 6.7(b) shall have ceased to be employed by the Target or shall have expressed an intention to terminate their employment with the Target or to decline to accept employment with the Buyer.”

Retention of Specified Employees of Target

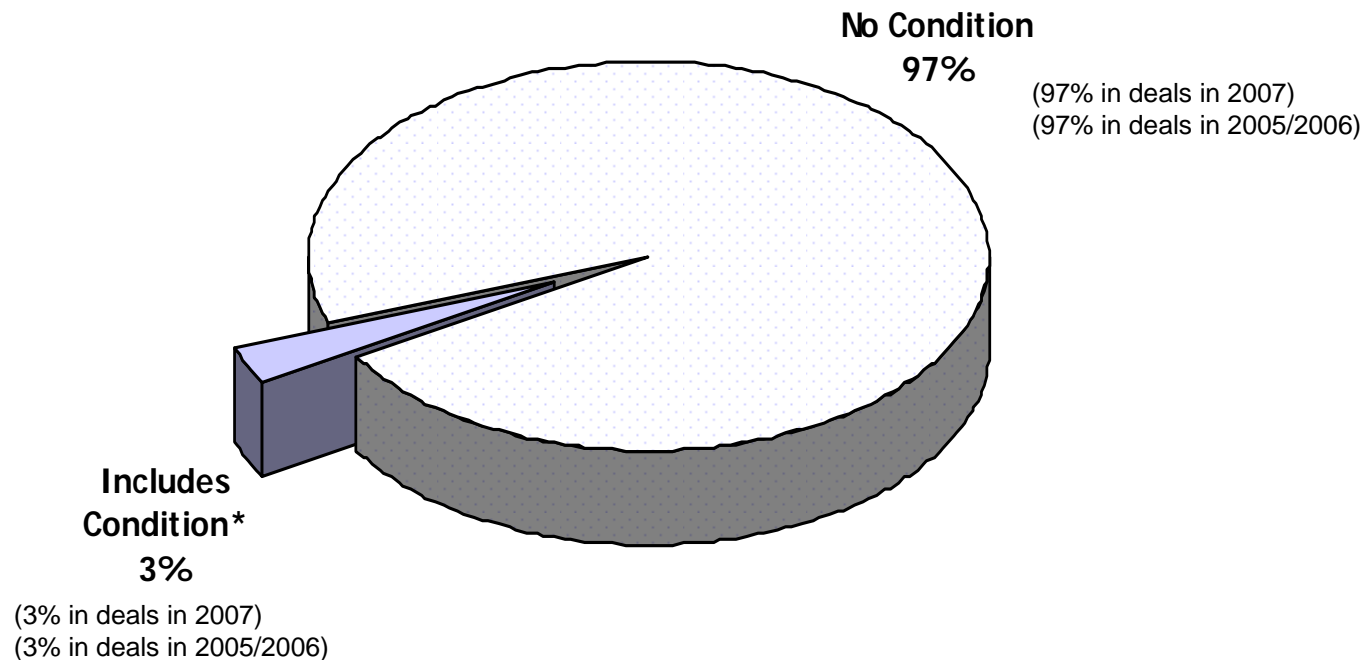

* The 3% statistic includes agreements requiring that certain employees enter into new agreements as well as agreements that have either or both of a “single employee” trigger and/or a “percentage of employees” trigger – see prior slide for examples. Condition to the effect that “employment agreements remain in full force and effect” are not included in the 3% statistic.

No Governmental Litigation Challenging the Transaction

“No Governmental Litigation. There shall not be pending or threatened any Legal Proceeding in which a Governmental Body is or is threatened to become a party. (a) challenging or seeking to restrain or prohibit the consummation of the Merger or any of the other transactions contemplated by this Agreement; (b) seeking to prohibit or limit in any material respect the Buyer’s ability to vote, receive dividends with respect to or otherwise exercise ownership rights with respect to the stock of the Surviving Corporation; or (c) seeking to compel the Target, the Buyer or any Subsidiary of the Buyer to dispose of or hold separate any material assets as a result of the Merger or any of the other transactions contemplated by this Agreement.”

No Governmental Litigation Challenging the Transaction

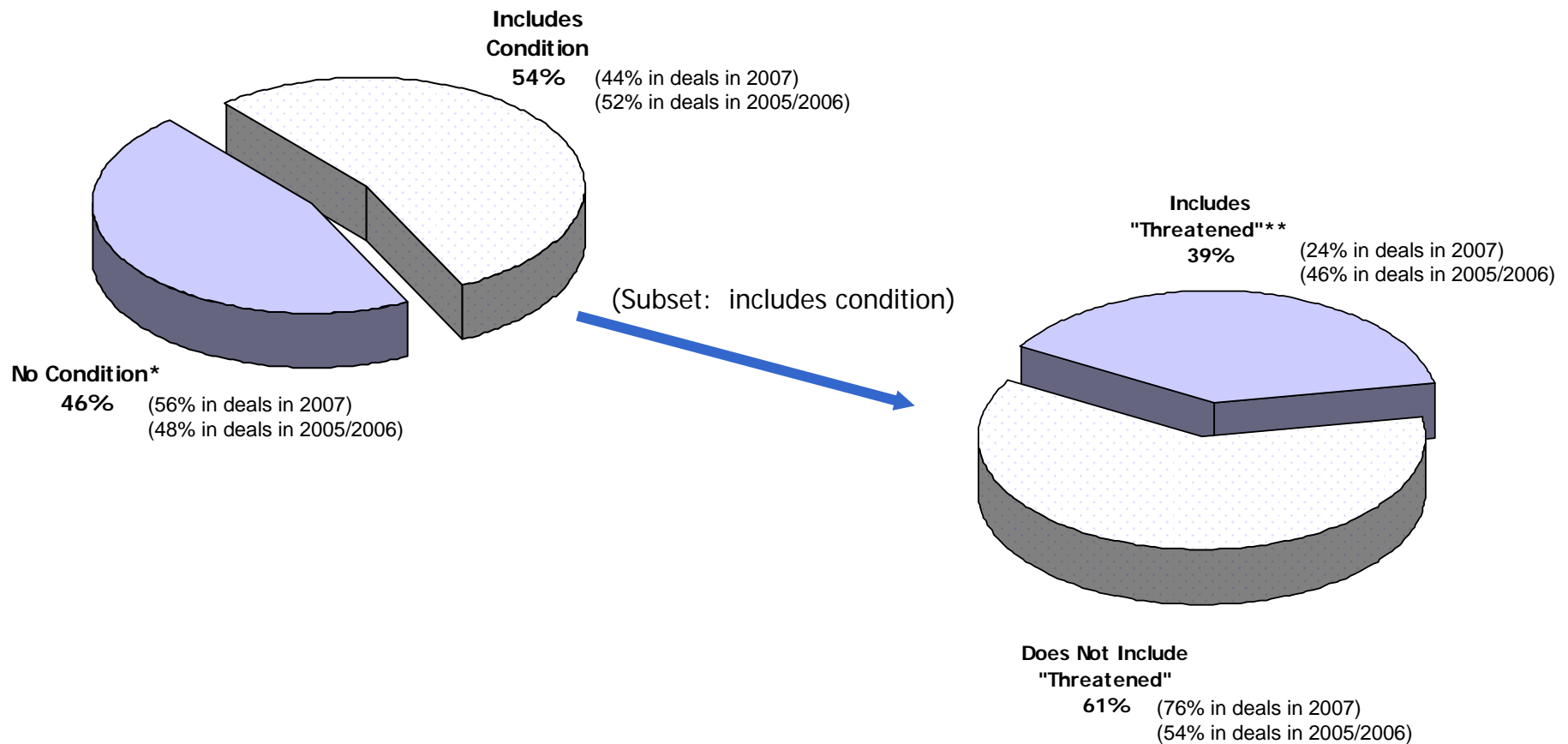

* Provisions requiring that the SEC shall not have entered or threatened a "stop order" are not treated as a No Governmental Litigation condition for purposes of this data point. Many of the agreements that did not include a specific "no governmental litigation" condition did include other provisions (such as a "material adverse change" condition or the "bring down" of the target's "no litigation" representation) that could, under certain circumstances, provide the buyer with a walk right in the event of governmental litigation relating to the transaction.

** Of the transactions in 2008 that included "threatened" governmental litigation, approximately 18% also included "in writing."

No Non-Governmental Litigation Challenging the Transaction

“No Other Litigation. There shall not be *pending or threatened* any Legal Proceeding in which *any Person* is or is threatened to become a party: (a) challenging or seeking to restrain or prohibit the consummation of the Merger or any of the other transactions contemplated by this Agreement; (b) seeking to prohibit or limit in any material respect the Buyer’s ability to vote, receive dividends with respect to or otherwise exercise ownership rights with respect to the stock of any of the Target; or (c) seeking to compel the Target, the Buyer or any Subsidiary of the Buyer to dispose of or hold separate any material assets as a result of the Merger or any of the other transactions contemplated by this Agreement.”

No Non-Governmental Litigation Challenging the Transaction

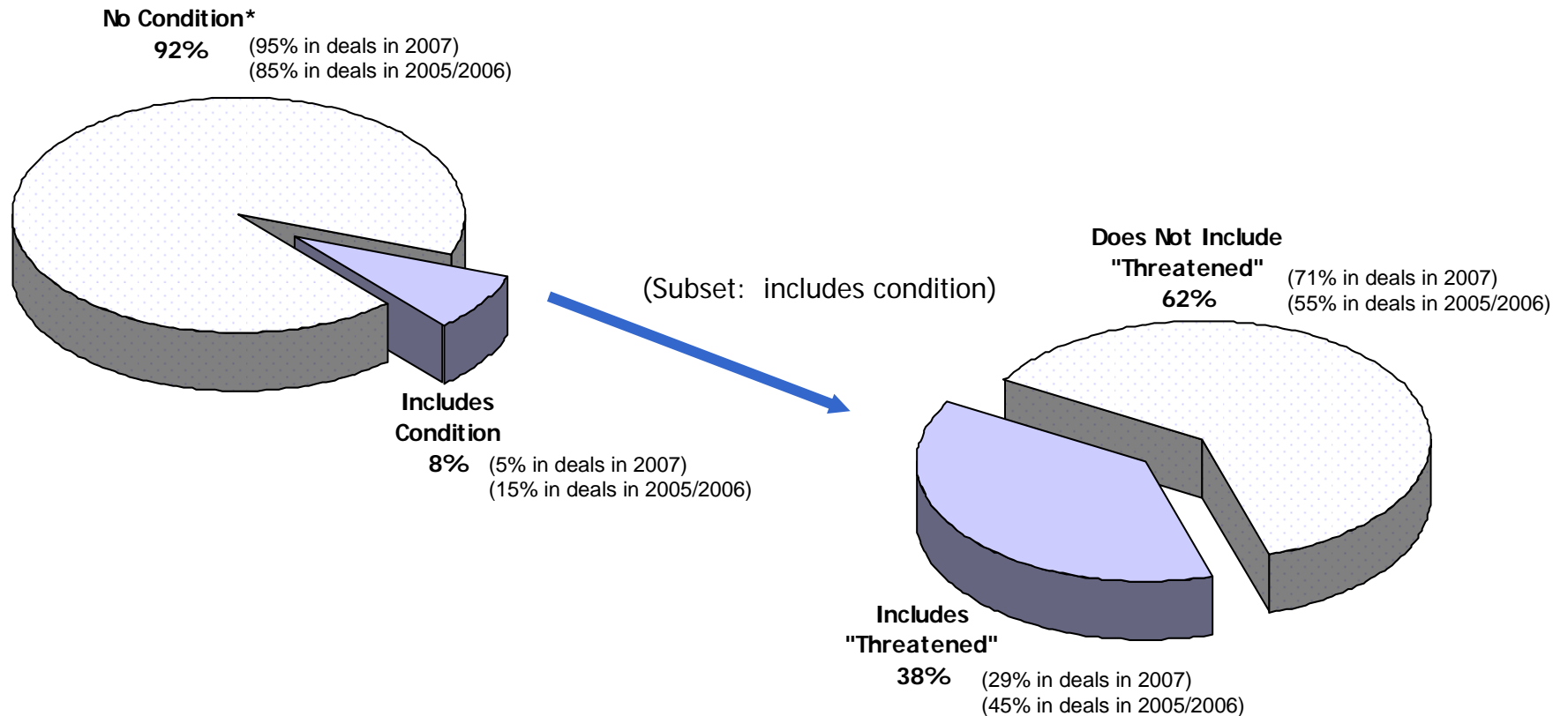

* Many of the agreements that did not include a specific “no non-governmental litigation” condition did include other provisions (such as a “material adverse change” condition or the “bring down” of the target’s “no litigation” representation) that could, under certain circumstances, provide the buyer with a walk right in the event of non-governmental litigation relating to the transaction.

Availability of Financing

“Financing. The Buyer shall have obtained the financing described in the Commitment Letters on the terms set forth in the Commitment Letters and on such other terms as are reasonably satisfactory to the Buyer.”

Availability of Financing*

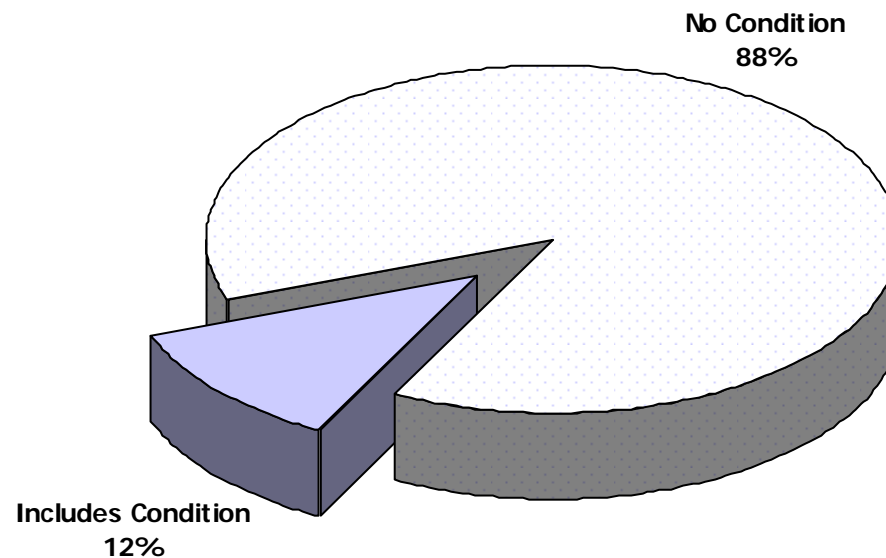

* Subset of transactions in which cash was included as consideration and where the buyer contemplated obtaining financing for the acquisition. For purposes of the data set, transactions which included (i) representations by the buyer regarding commitment letters (or similar obligations) with respect to obtaining financing, or (ii) covenants on behalf of the buyer to use specified efforts to obtain referenced financing prior to closing were deemed transactions where the buyer contemplated obtaining financing for the acquisition. Transactions that contained buyer representations generally providing that buyer would have “funds available at closing” were not deemed transactions where the buyer contemplated obtaining financing for the acquisition.

Receipt/Bring Down of Fairness Opinion by Target Advisor

“Fairness Opinion. The opinion of [Investment Banker] to the effect that the Exchange Ratio is fair, from a financial point of view, to the shareholders of the Target shall not have been withdrawn and shall be in full force and effect.”

Receipt/Bring Down of Fairness Opinion by Target Advisor

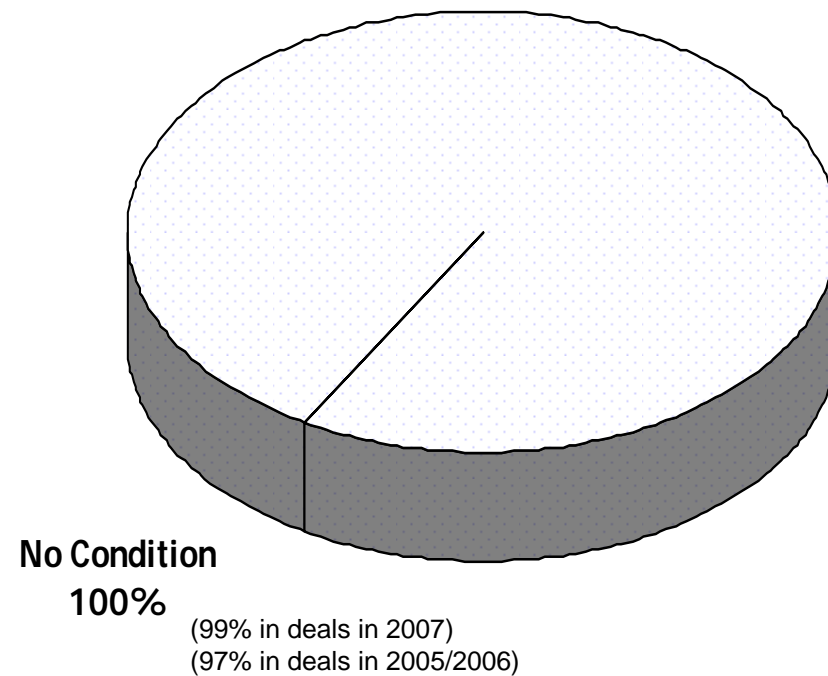

Appraisal Rights

“Appraisal Rights. The aggregate number of shares of Target Common Stock at the effective time of the Merger, the holders of which have demanded purchase of their shares of Target Common Stock in accordance with the provisions of Section 262 of the DGCL, shall not equal [10]% or more of the shares of Target Common Stock outstanding as of the record date for the Target Stockholders Meeting.”

Appraisal Rights*

All Cash

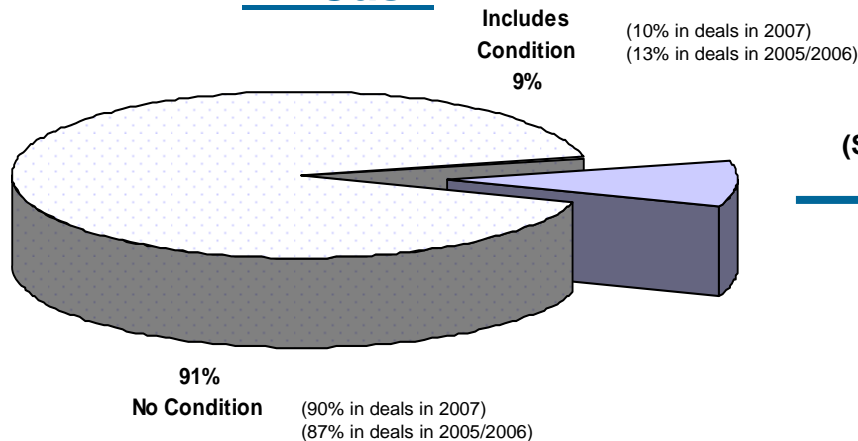

(Subset: Includes Condition)

Appraisal Rights Cap	Number of Deals
10% - 15%	4 out of 6
5% - 9.9%	2 out of 6

All Cash

Part Cash/Part Stock

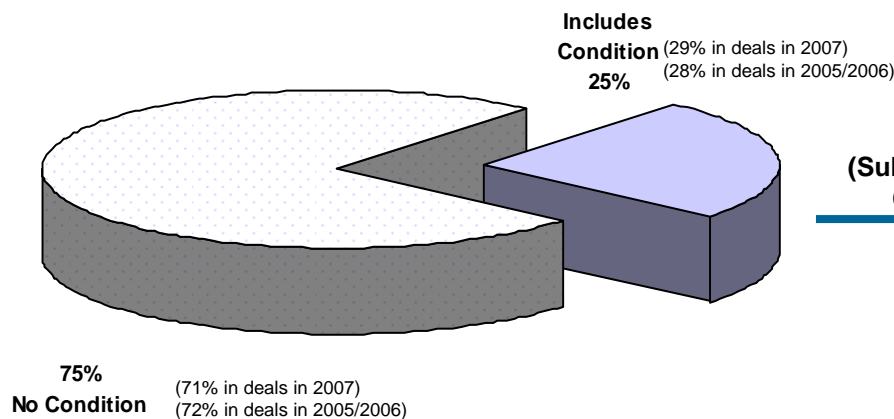

(Subset: Includes Condition)

Appraisal Rights Cap	Number of Deals
More than 15%	1 out of 5
10% - 15%	3 out of 5
5% - 9.9%	1 out of 5

Part Cash/Part Stock

* Stock-for-stock deals are not included in the data set, as appraisal rights are generally not available in stock-for-stock transactions between two public companies due to the "market out" exception in Section 262 of the Delaware General Corporation Law. Other jurisdictions have similar statutory provisions.

Deal Protection and Related Provisions

Target No-Shop/No-Talk; Fiduciary Exception to No-Talk

“No Solicitation. The Target shall not directly or indirectly, and shall not authorize or permit any of the other Acquired Corporations or any Representative of any of the Acquired Corporations directly or indirectly to: (a) solicit, initiate, encourage, induce or facilitate the making, submission or announcement of any Acquisition Proposal . . .; (b) furnish any nonpublic information regarding any of the Acquired Corporations to any Person in connection with or in response to an Acquisition Proposal or an inquiry or indication of interest that could lead to an Acquisition Proposal; (c) engage in discussions or negotiations with any Person with respect to any Acquisition Proposal; (d) . . .;”

Fiduciary Exception to No-Talk

“provided, however, that prior to the approval of this Agreement by the Required Target Stockholder Vote, this Section 4.3(a) shall not prohibit the Target from furnishing nonpublic information regarding the Acquired Corporations to, or entering into discussions with, any Person **in response to [an Acquisition Proposal] [an Acquisition Proposal that is reasonably likely to result in a Superior Offer] [a Superior Offer]** that is submitted to the Target by such Person (and not withdrawn) if . . .”

Fiduciary Exception to No-Talk*

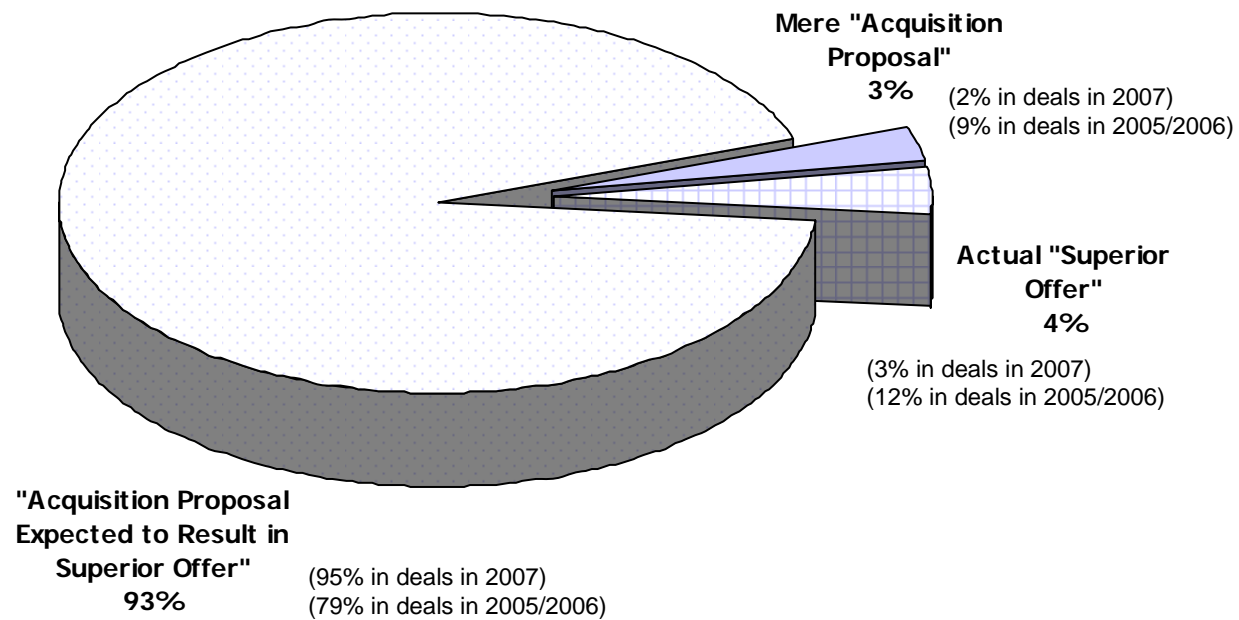

* Excludes two transactions in 2008 that did not contain a fiduciary exception to the no-talk provision.

Fiduciary Exception to No-Talk Acquisition Proposal vs. Superior Offer Stock and Asset Tests

“**Acquisition Proposal** means any offer, proposal, inquiry or indication of interest from any Third Party relating to any transaction involving (i) any acquisition or purchase by any Person . . . of **15% or more** of any class of outstanding voting or equity securities of the Company, . . . (ii) any merger, consolidation, business combination, or other similar transaction involving the Company or any of its Subsidiaries, the business of which constitutes **15% or more** of the net revenues, net income or assets of the Company and its Subsidiaries, taken as a whole, (iii) any sale, lease, exchange, transfer, license acquisition or disposition of **15% or more** of the assets of the Company and its Subsidiaries, taken as a whole or (iv) any liquidation, dissolution, recapitalization, extraordinary dividend or other significant corporate reorganization of the Company or any of its Subsidiaries, the business of which constitutes **15% or more** of the net revenues, net income or assets of the Company and its Subsidiaries, taken as a whole.”

“**Superior Offer** means any bona fide, unsolicited, written Acquisition Proposal . . . made by a Third Party, which, if consummated would result in such Third Party . . . owning . . . **all of the outstanding shares** of Company Common Stock, or **all or substantially all of the consolidated assets of the Company and its Subsidiaries** . . .”

Fiduciary Exception to No-Talk What Percentage of Target Stock Constitutes a "Superior Offer?"*

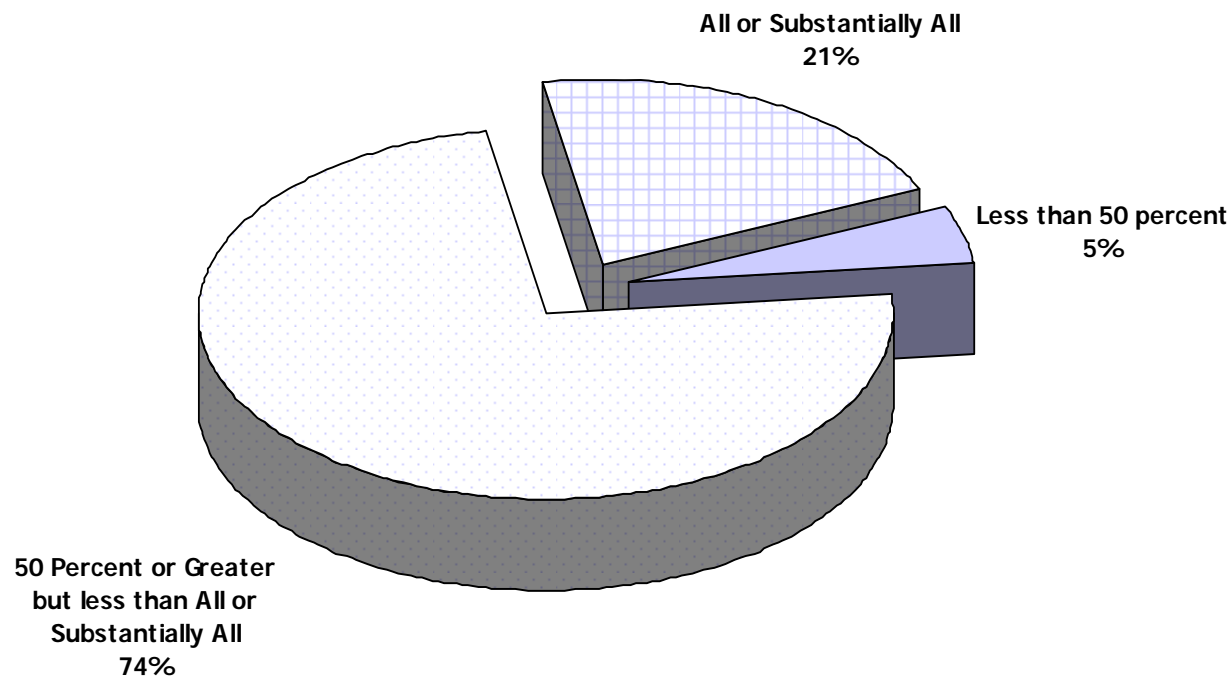

* Excludes four transactions, two of which did not contain a no-talk provision or a fiduciary exception to the no-talk provision, and two where the standard was indeterminable.

Fiduciary Exception to No-Talk What Percentage of Target Assets Constitutes a "Superior Offer?"*

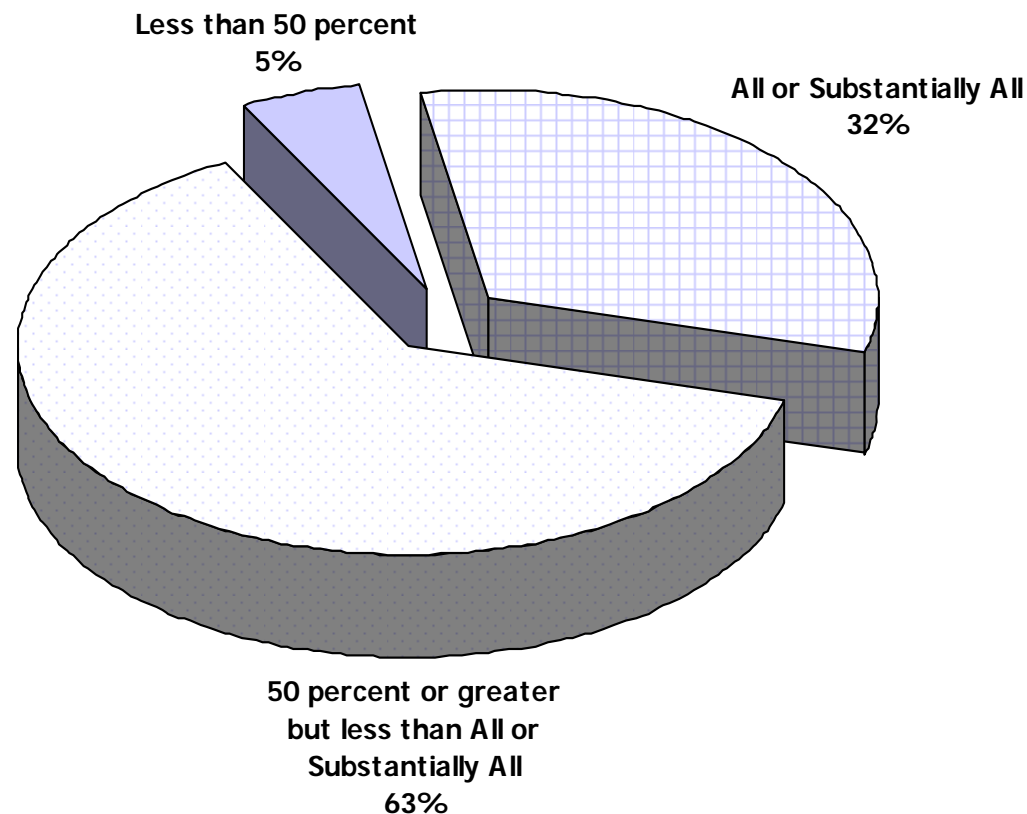

* Excludes seven transactions, three of which did not contain an asset test, two of which did not contain a no-talk provision or fiduciary exception to the no-talk provision, and two where the standard was indeterminable.

Go Shop

“Go Shop. During the period beginning on the date of this Agreement and continuing until 11:59 p.m. (EST) on the date that is [25] days after the date hereof . . . , the Target . . . shall have the right . . . to directly or indirectly: (i) initiate, solicit and encourage Acquisition Proposals, including by way of providing access to non-public information pursuant to one or more Acceptable Confidentiality Agreements, provided that the Target shall promptly provide to the Buyer any material non-public information concerning the Target or its Subsidiaries that is provided to any Person given such access which was not previously made available to the Buyer; and (ii) enter into and maintain discussions or negotiations with respect to potential Acquisition Proposals or otherwise cooperate with or assist or participate in, or facilitate, any such inquiries, proposals, discussions or negotiations.”

Go Shop

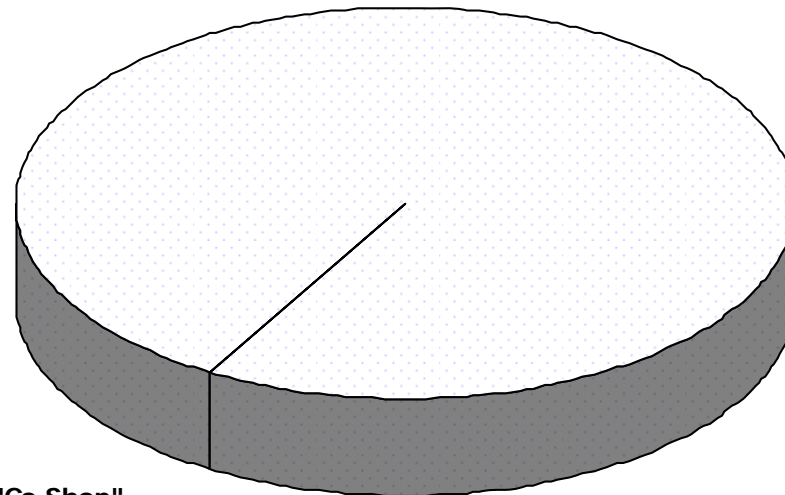

No "Go Shop"
100%

(97% in deals in 2007)
(100% in deals in 2005/2006)

Fiduciary Exception to Target Board Recommendation Covenant ("Fiduciary Duties")

“Notwithstanding anything to the contrary contained in Section 5.2(b), at any time prior to the approval of this Agreement by the Required Target Stockholder Vote, the Target Board Recommendation may be withdrawn or modified in a manner adverse to the Buyer **if the Target’s board of directors determines in good faith . . . that the withdrawal or modification of the Target Board Recommendation is required in order for the Target’s board of directors to comply with its fiduciary obligations to the Target’s stockholders under applicable law . . .**”

Fiduciary Exception to Target Board Recommendation Covenant (Limited to a “Superior Offer”)

“Notwithstanding anything to the contrary contained in Section 5.2(b), at any time prior to the approval of this Agreement by the Required Target Stockholder Vote, the Target Board Recommendation may be withdrawn or modified in a manner adverse to the Buyer if: (i) **an unsolicited, bona fide written offer** . . . is made to the Target and is not withdrawn . . . (ii) the Target’s board of directors determines in good faith (based upon a written opinion of an independent financial advisor of nationally recognized reputation) **that such offer constitutes a Superior Offer**; and (iii) the Target’s board of directors determines in good faith . . . that, in light of such Superior Offer, the withdrawal or modification of the Target Board Recommendation is required in order for the Target’s board of directors to comply with its fiduciary obligations to the Target’s stockholders under applicable law . . .”

Fiduciary Exception to Target Board Recommendation Covenant (Limited to a “Superior Offer/Intervening Event”)

“Notwithstanding anything to the contrary contained in Section 5.2(b), at any time prior to the approval of this Agreement by the Required Target Stockholder Vote, the Target Board Recommendation may be withdrawn or modified in a manner adverse to the Buyer if: (A)(i) an unsolicited, bona fide written offer... is made to the Target and is not withdrawn... and the Target’s board of directors determines in good faith (based upon a written opinion of an independent financial advisor of nationally recognized reputation) that such offer constitutes a Superior Offer; or (ii) **a material development or change in circumstances occurs or arises after the date of this Agreement [that was not known by the Target’s board of directors as of the date of this Agreement] (such material development or change in circumstances being referred to as an “Intervening Event”)**, and (B) the Target’s board of directors determines in good faith . . . that, in light of such Superior Offer **or such Intervening Event**, the withdrawal or modification of the Target Board Recommendation is required in order for the Target’s board of directors to comply with its fiduciary obligations to the Target’s stockholders under applicable law . . .”

Fiduciary Exception to Target Board Recommendation Covenant*

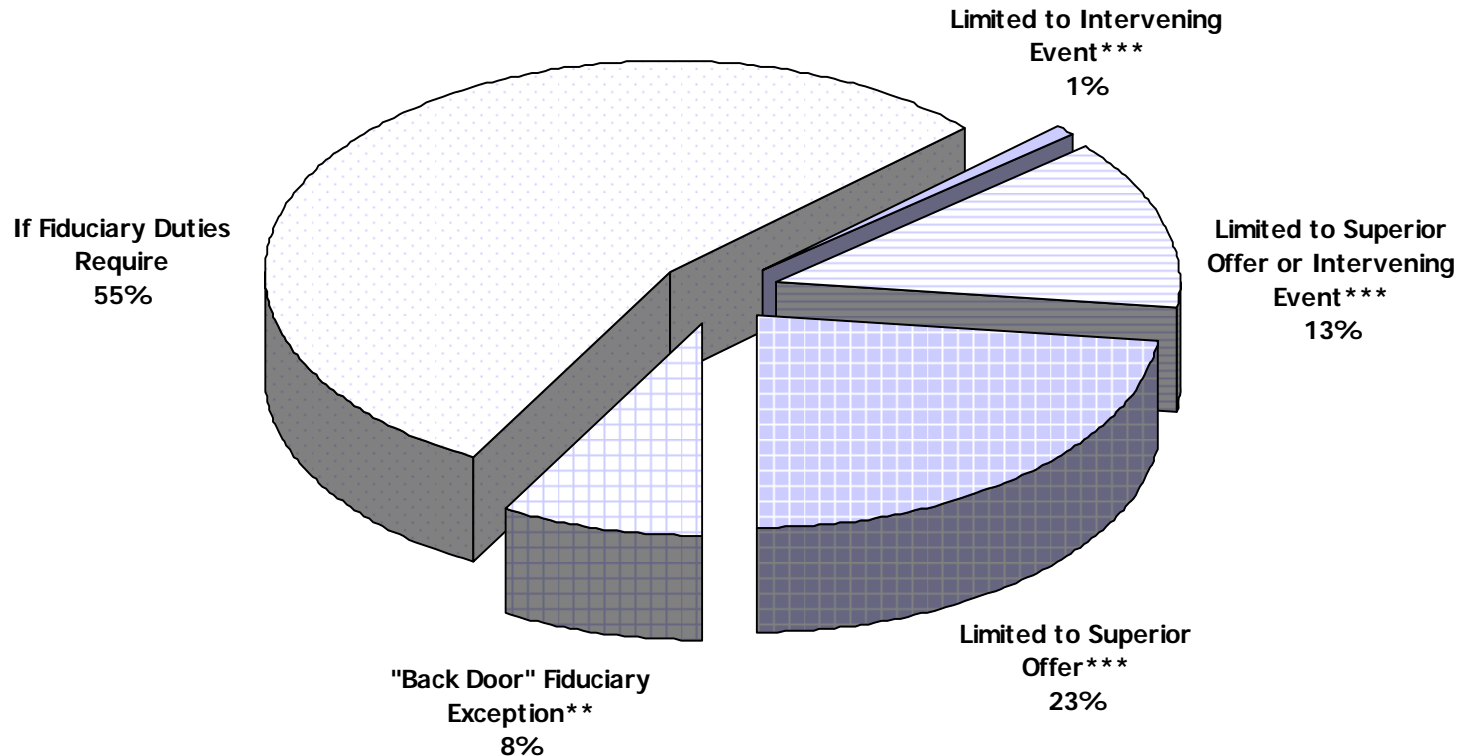

- * Two transactions were excluded from the main study sample because the relevant acquisition agreement did not include a customary fiduciary exception to the recommendation covenant.
- ** Eight transactions in the study included a “back-door” fiduciary exception to the change in recommendation (a provision expressly limiting the target board’s ability change its recommendation to a Superior Offer or an Intervening Event, but also expressly providing the target board the ability to take any action and/or disclose material information to the target’s stockholders if required by its fiduciary duties under applicable law).
- *** Substantially all of the transactions in which the fiduciary exception was limited to a Superior Offer and/or an Intervening Event also included an additional provision generally requiring the target board to also determine that, in light of such Superior Proposal or Intervening Event, its fiduciary duties required the board to change its recommendation.

Target Fiduciary (Superior Offer) Termination Right

“Termination. This Agreement may be terminated at any time prior to the Effective Time . . . (f) by the Target if: (i) the Target Stockholder Approval has not been obtained; and (ii) concurrently the Target enters into a definitive Target Acquisition Agreement providing for a Superior Offer in accordance with Section 5.3; *provided that [first pay “break-up” fee].*”

Target Fiduciary (Superior Offer) Termination Right

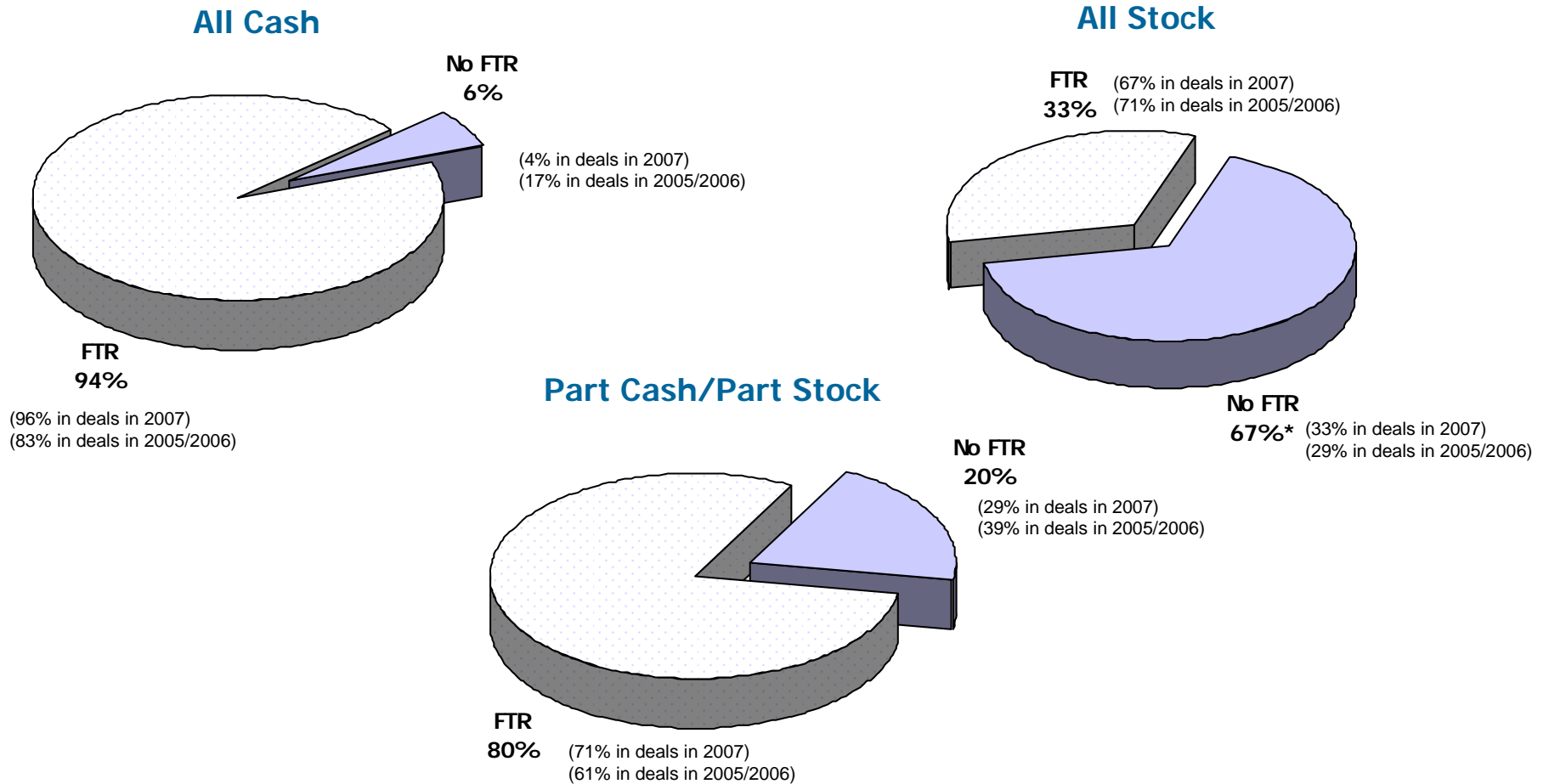

* Six of the ten all-stock deals in 2008 that did not contain a fiduciary (superior offer) termination right involved financial institution target companies in a highly distressed environment.

Buyer “Match Right” Relating to Target Fiduciary (Superior Offer) Termination Right

“**Termination.** This Agreement may be terminated at any time prior to the Effective Time . . . (f) by the Target if: (i) the Target Stockholder Approval has not been obtained; (ii) **(A) the Target Board has determined that an Acquisition Proposal constitutes a Superior Offer, (B) Target has provided notice to Buyer of such determination, (C) Target has negotiated in good faith with Buyer to amend the terms of this Agreement so that the Superior Offer would no longer constitute a Superior Offer, (D) [five] business days have elapsed since such notice to Buyer and the Acquisition Proposal remains a Superior Offer,** and (iii) concurrently with the termination under this subsection (f), the Target enters into a definitive Target Acquisition Agreement providing for the Superior Offer; *provided that [first pay “break-up” fee].*”

Buyer “Match Right” Relating to Target Fiduciary (Superior Offer) Termination Right*

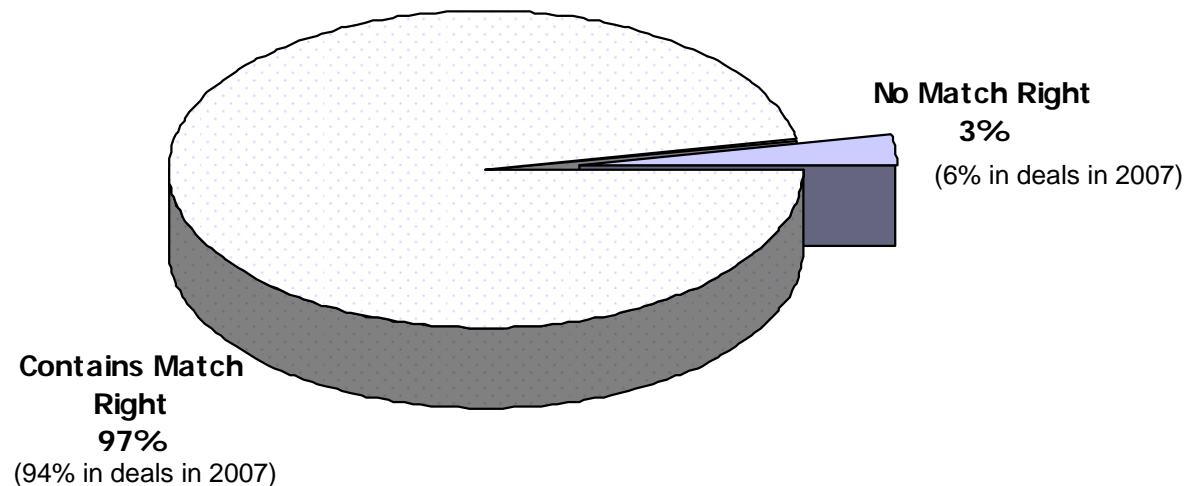

* Only agreements providing a fiduciary (superior offer) termination right that also expressly provided the buyer with the right to “match” the superior offer prior to the target’s ability to terminate the agreement are listed as having a “match right.” Three agreements studied contained other provisions (such as notification rights and restrictions on the ability of the Target to terminate for a specified period of time) which may effectively give the buyer a match right, but were not included because such provision did not explicitly grant that right. Many of the agreements studied also included a match right concept with respect to the ability of the Target board to change its recommendation.

Match Right Period Superior Offer

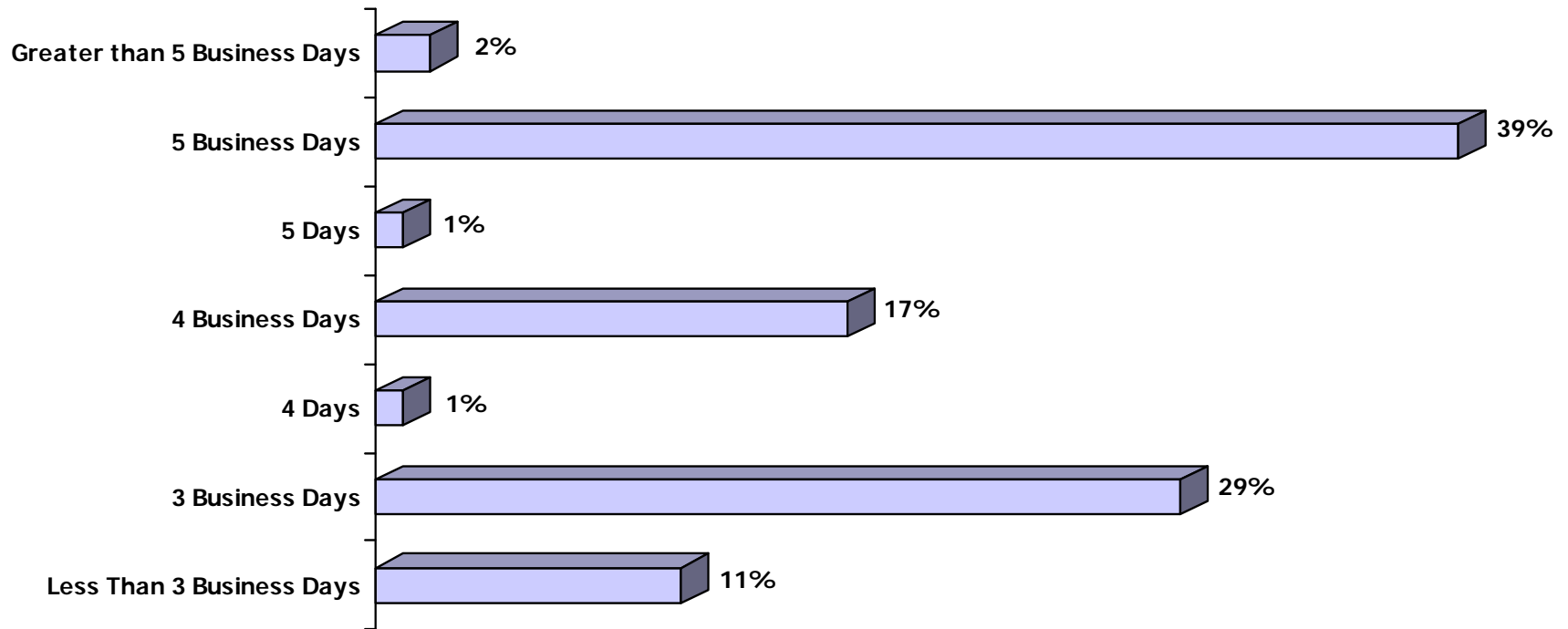

Target “Break-Up” Fee Triggers

“8.3 Expenses; Termination Fees.

(a) Except as set forth in this Section 8.3, all fees and expenses incurred in connection with this Agreement and the transactions contemplated by this Agreement shall be paid by the party incurring such expenses, whether or not the Merger is consummated; *provided, however*, that:

(i) [**Naked No-Vote Fee**] If this Agreement is terminated by the Buyer or the Target pursuant to Section 8.1(d) [*“no vote”*], then the Target shall [reimburse the Buyer for all expenses incurred by the Buyer in connection with the Merger] [pay to the Buyer, in cash, a nonrefundable fee in the amount of \$_____].

(ii) [**Fee for No-Vote + Acquisition Proposal**] If this Agreement is terminated by the Buyer or the Target pursuant to Section 8.1(d) [*“no vote”*] **and** at or prior to the time of the termination of this Agreement an Acquisition Proposal shall have been made, then the Target shall pay to the Buyer, in cash, a nonrefundable fee in the amount of \$_____.

(iii) [**Drop-Dead Date + Acquisition Proposal**] If this Agreement is terminated by the Buyer or the Target pursuant to Section 8.1(b) [*drop dead date*] **and** at or prior to the time of the termination of this Agreement an Acquisition Proposal shall have been made, then the Target shall pay to the Buyer, in cash, a nonrefundable fee in the amount of \$_____.

(iv) [**Change in Board Recommendation; Certain Breaches**] If this Agreement is terminated by the Buyer pursuant to Section 8.1(e) [*change in Board Recommendation*], Section 8.1(f) [*breach of no shop or meeting covenants*] or Section 8.1(g) [*breach of representations, warranties or covenants*], then the Target shall pay to the Buyer, in cash, a nonrefundable fee in the amount of \$_____.”

Target "Break-Up" Fee Triggers ("Naked No-Vote")*

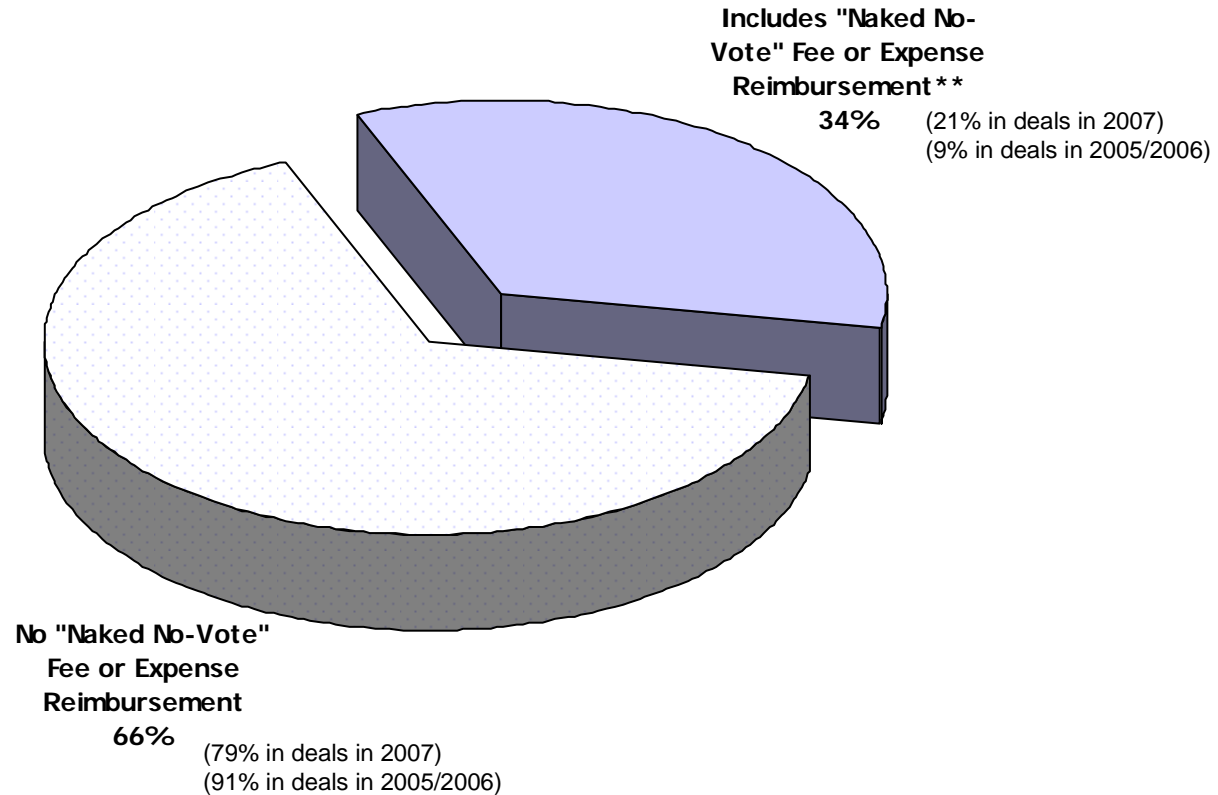

- * Excludes 36 tender offers and five transactions with no break-up fee provisions (all of which were financial institution targets).
- ** Out of the 21 transactions that contained a "naked no-vote" trigger, 17 required reimbursement of expenses only, two required payment of a full break-up fee (i.e., the same dollar amount as the break-up fee payable in other contexts) and two required payment of a partial break-up fee.

Target "Break-Up" Fee Triggers ("No-Vote" + Acquisition Proposal)*

Must Acquisition Proposal be Pending?

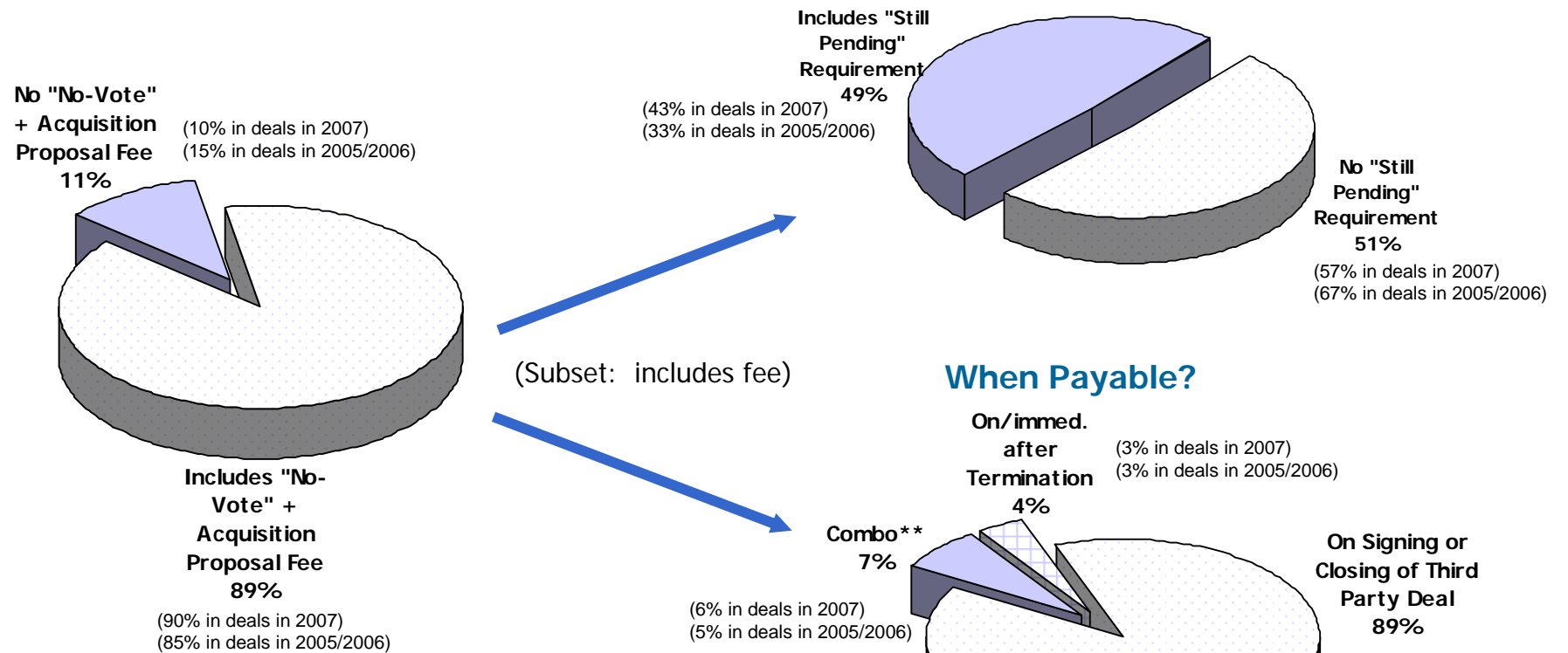

* Excludes 36 tender offers and five transactions in 2008 with no break-up fee provisions (all of which were financial institution targets).

** Part of fee payable on/immediately after termination and part of fee payable on signing or consummation of third party deal.

Target "Break-Up" Fee Triggers (Drop Dead Date + Acquisition Proposal)*

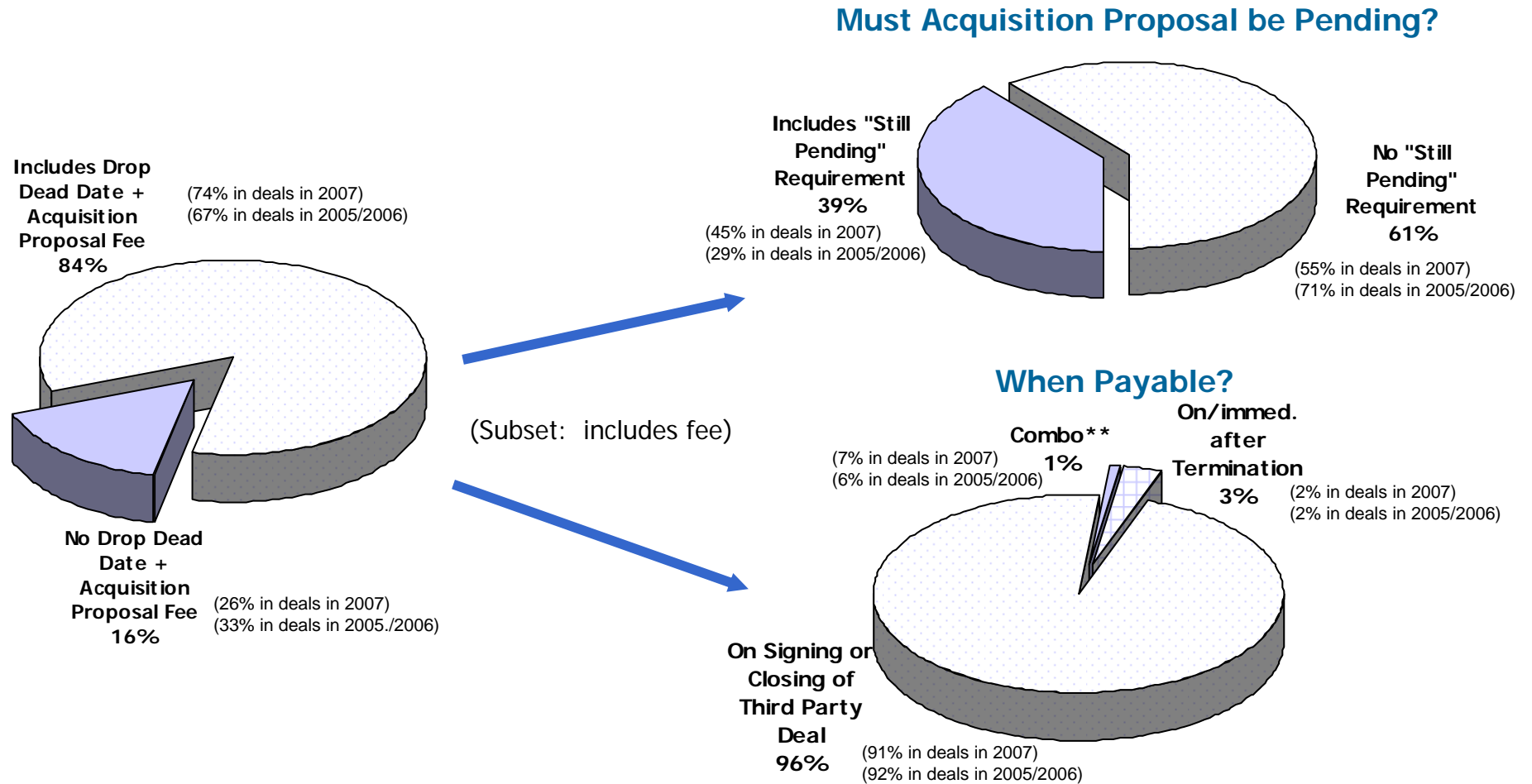

* Excludes five transactions in 2008 with no break-up fee provisions (all of which were financial institution targets).

** Part of fee payable on/immediately after termination and part of fee payable on signing or consummation of third party deal.

Target "Break-Up" Fee Triggers (Change of Board Recommendation)*

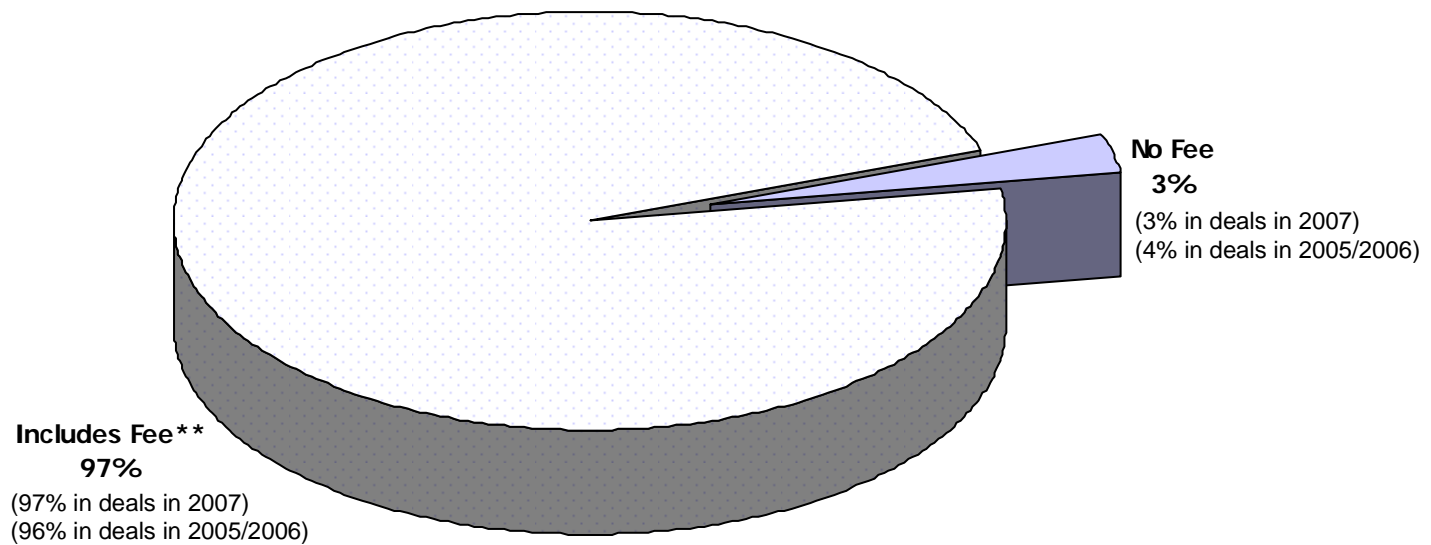

- * Excludes five transactions in 2008 with no break-up fee provisions (all of which were financial institution targets).
- ** 7% of the transactions in 2008 providing for a fee in this instance contain conditions in addition to mere change or withdrawal of the target board's recommendation, such as consummation of a third party deal within a specified period after termination.

Target "Break-Up" Fee Triggers (Breach of Acquisition Agreement)*

General Breach**

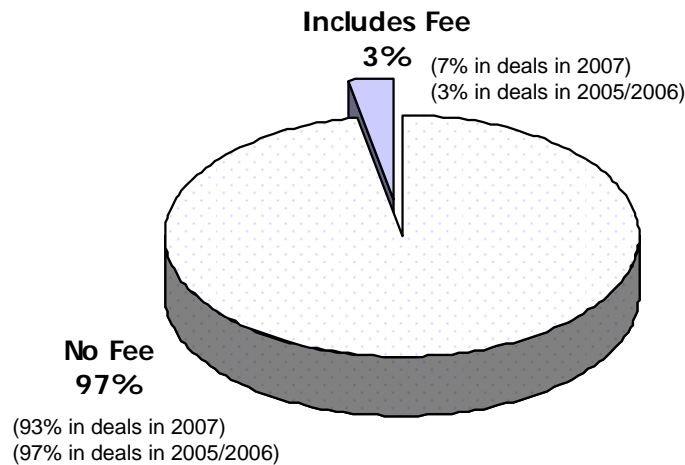

Breach No-Shop***

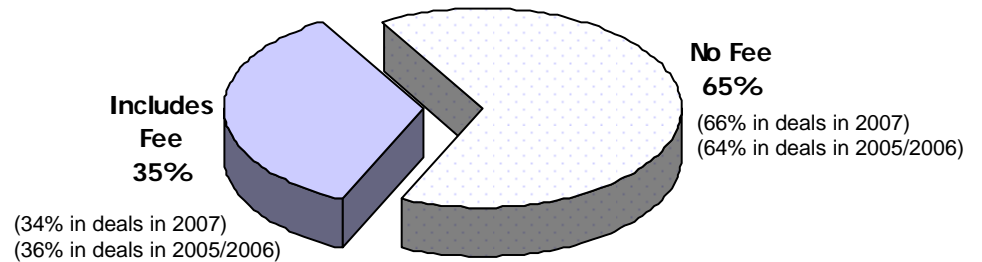

Breach Stockholder Meeting Covenants

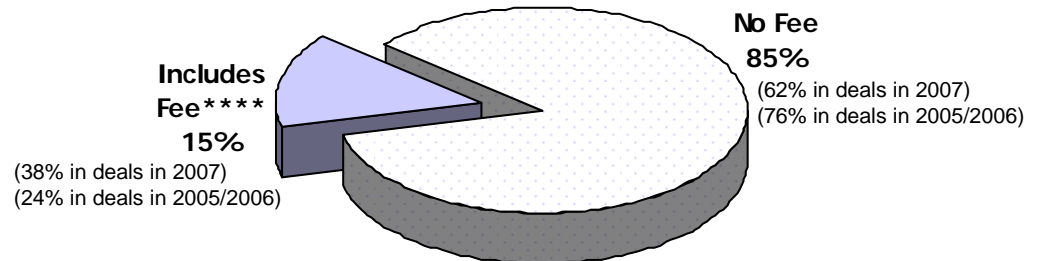

* Excludes five transactions in 2008 with no break-up fee provisions (all of which were financial institution targets).

** General breach of representations, warranties and covenants: (a) is limited to transactions in which mere breach, without other conditions (such as consummation of a third party bid), triggers a break-up fee; and (b) do not include transactions in which a breach triggers reimbursement of expenses rather than full break-up fee.

*** Breach of no-shop covenants: (a) do not include general breach of representations, warranties and covenants; and (b) are limited to transactions in which mere breach, without other conditions, triggers a break-up fee. Approximately 50% of the transactions in 2008 including a fee for the breach of the no-shop covenants require a willful, material or intentional breach.

**** Breach of stockholder meeting covenants: (a) do not include general breach of representations, warranties and covenants; (b) are limited to transactions in which mere breach, without other conditions, triggers a break-up fee; and (c) excludes tender offers. Approximately 20% of the transactions in 2008 including a fee for the breach of the stockholder meeting covenants required a willful or material breach, and one transaction provided for payment of expenses at a capped amount, rather than the full breakup fee.

Other Acquisition Agreement Data Points

Operating Covenant

Operate in Ordinary Course – Affirmative Covenant

(Flat Covenant)

“**Conduct of Business Prior to Effective Time.** The Company shall, and shall cause each of the Company Subsidiaries to, **conduct its business in the ordinary course [consistent with past practice]** . . .”

(Covenant Modified by “Efforts”)

“**Conduct of Business Prior to Effective Time.** The Company shall **use its [reasonable/commercially reasonable] efforts**, and shall cause each of the Company Subsidiaries to **use its [reasonable/commercially reasonable] efforts** to, conduct its business in the ordinary course [consistent with past practice] . . .”

Operating Covenant Operating in Ordinary Course – Affirmative Covenant*

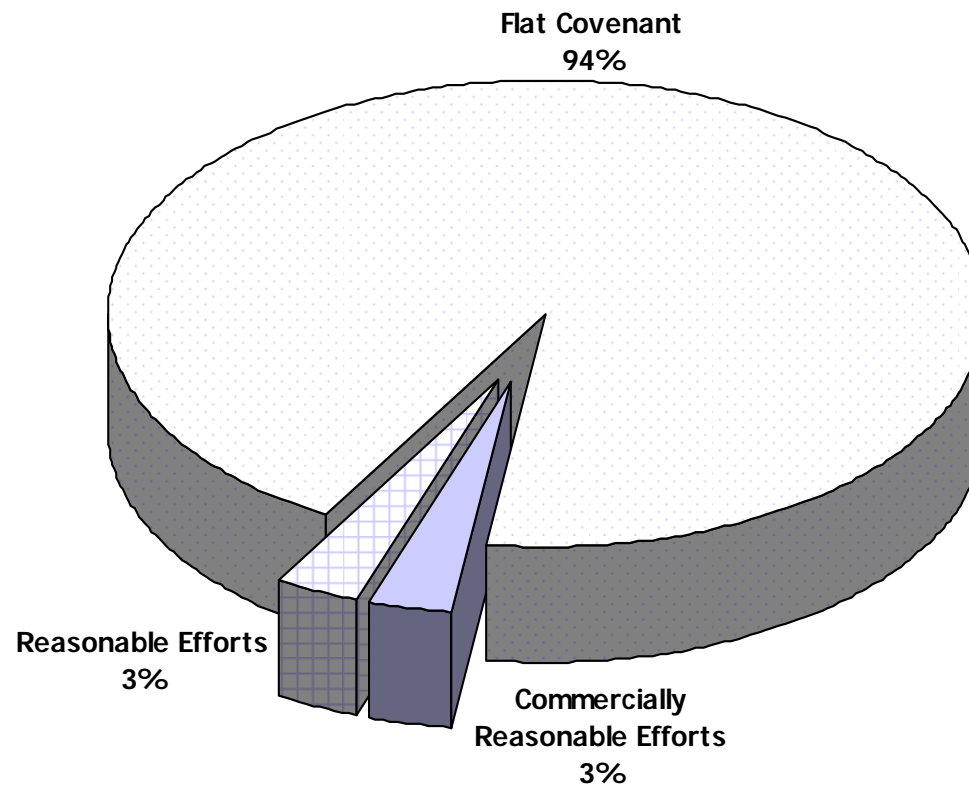

* Excludes one transaction in 2008 (involving a financial institution target) that did not contain a traditional target operating covenant.

Operating Covenant Operate in Ordinary Course – Affirmative Covenant “Consistent with Past Practice” Included?*

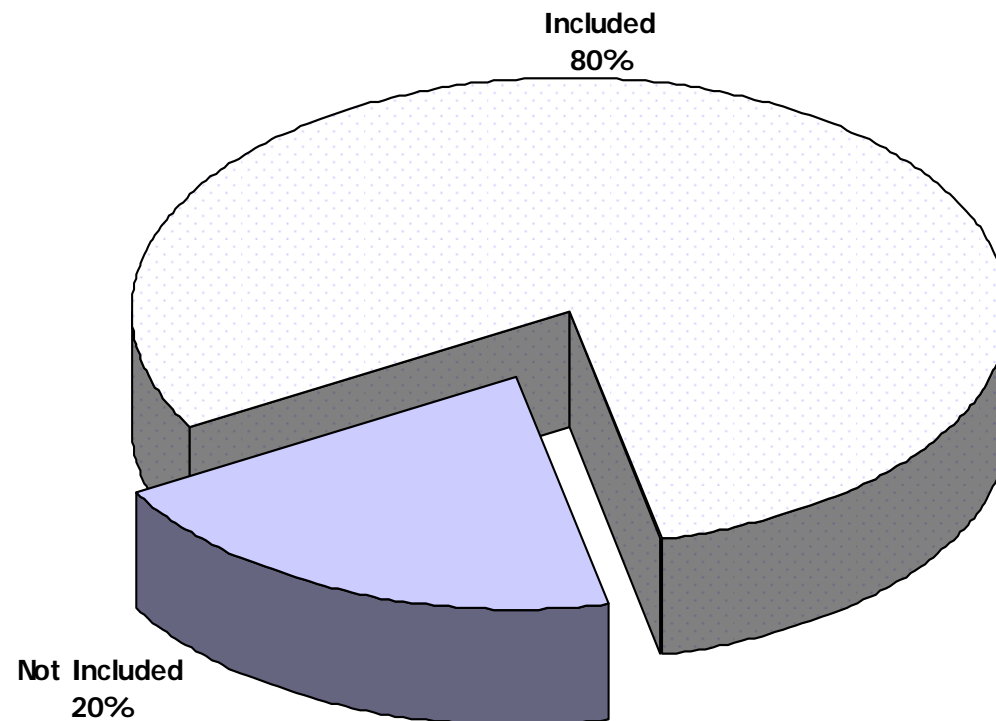

* Excludes one transaction in 2008 (involving a financial institution target) that did not contain a traditional target operating covenant.

Operating Covenant Negative Covenant Parent Consent Requirement

(Flat Consent)

“**Company Forbearances.** During the period from the date of this Agreement and continuing until the Effective Time . . . , the Company shall not, and shall not permit any of the Company Subsidiaries to, **without the prior written consent of Parent . . .**”

(Consent “not unreasonably withheld”)

“**Company Forbearances.** During the period from the date of this Agreement, and continuing until the Effective Time, . . . the Company shall not, and shall not permit any of the Company Subsidiaries to, without the prior written consent of Parent (**which consent shall not be unreasonably withheld**) . . .”

Operating Covenant Negative Covenant Parent Specifically Restricted From Unreasonably Withholding Consent?*

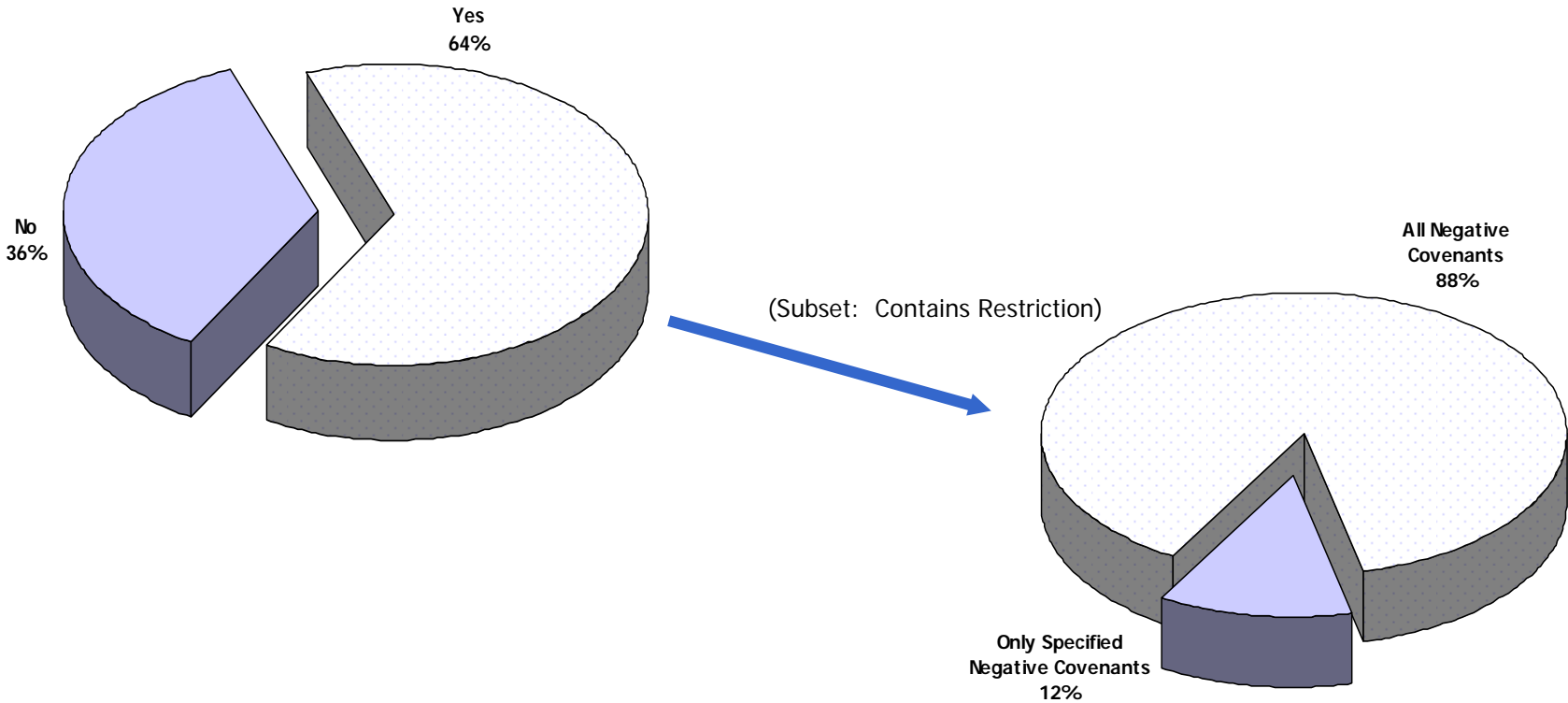

* Excludes one transaction in 2008 (involving a financial institution target) that did not contain a traditional target operating covenant.

D&O Insurance

“D&O Insurance. From the Effective Time until the ___ anniversary of the Effective Time, the Surviving Corporation shall maintain in effect, for the benefit of the Indemnified Persons with respect to their acts and omissions occurring prior to the Effective Time, the existing policy of directors’ and officers’ liability insurance maintained by the Target as of the date of this Agreement in the form disclosed by the Target to the Buyer prior to the date of this Agreement (the “Existing Policy”); *provided, however,* that: (i) the Surviving Corporation may substitute for the Existing Policy a policy or policies of comparable coverage; and (ii) the Surviving Corporation shall not be required to pay annual premiums for the Existing Policy (or for any substitute policies) in excess of \$_____ in the aggregate [**150%** of the current premium]....

D&O Insurance

Time Period

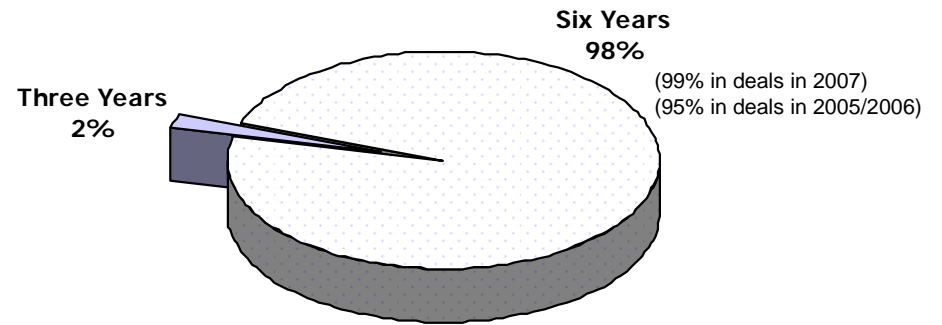
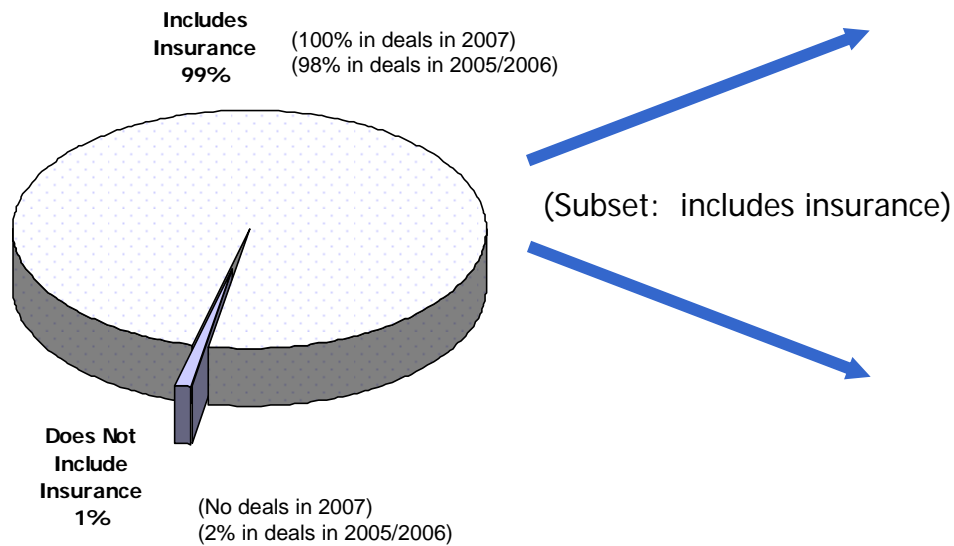

Premium Cap/Percentage of Deals*

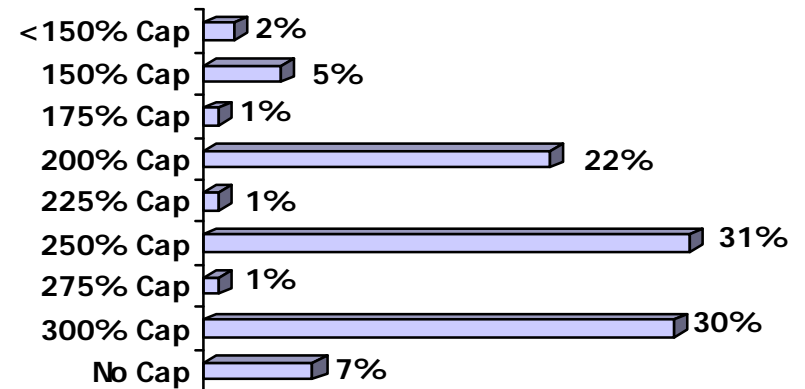

* Excludes eight deals in 2008 where the premium cap was not determinable.

Choice of Law

“Governing Law. This Agreement is made under, and shall be construed and enforced in accordance with, the laws of the State of [Delaware] applicable to agreements made and to be performed solely therein, without giving effect to principles of conflicts of law.”

Choice of Law*

Target incorporated in Delaware

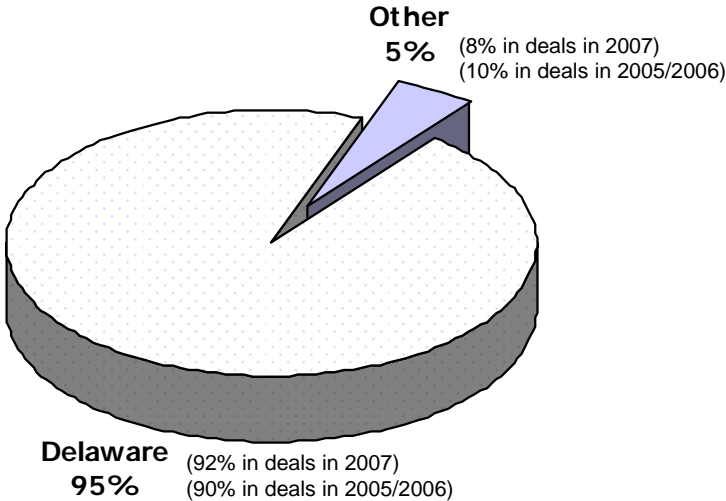

Target *not* incorporated in Delaware

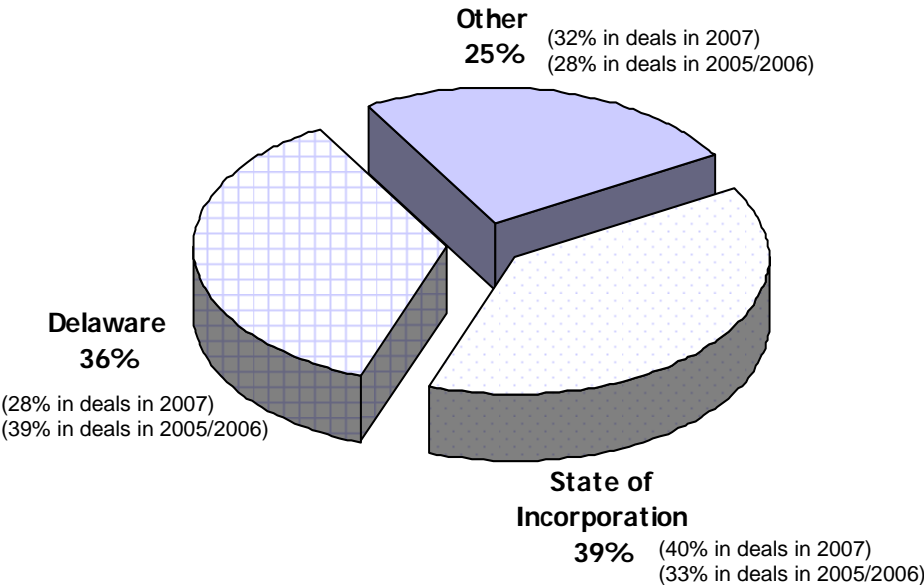

* The choice of law identified in the charts above refers to the law applicable to matters other than certain matters, such as the merger mechanics, that are mandatorily governed by the law of the jurisdiction of incorporation.

No Other Representations

“No Other Representations. The Buyer acknowledges that the Target has not made and is not making any representations or warranties whatsoever regarding the subject matter of this Agreement, express or implied, except as provided in Section 3.”

No Other Representations/Non-Reliance

“No Other Representations; Non-Reliance. The Buyer acknowledges that the Target has not made and is not making any representations or warranties whatsoever regarding the subject matter of this Agreement, express or implied, except as provided in Section 3, **and that it is not relying and has not relied on any representations or warranties whatsoever regarding the subject matter of this Agreement, express or implied, except as provided in Section 3.**”

No Other Representations/Non-Reliance

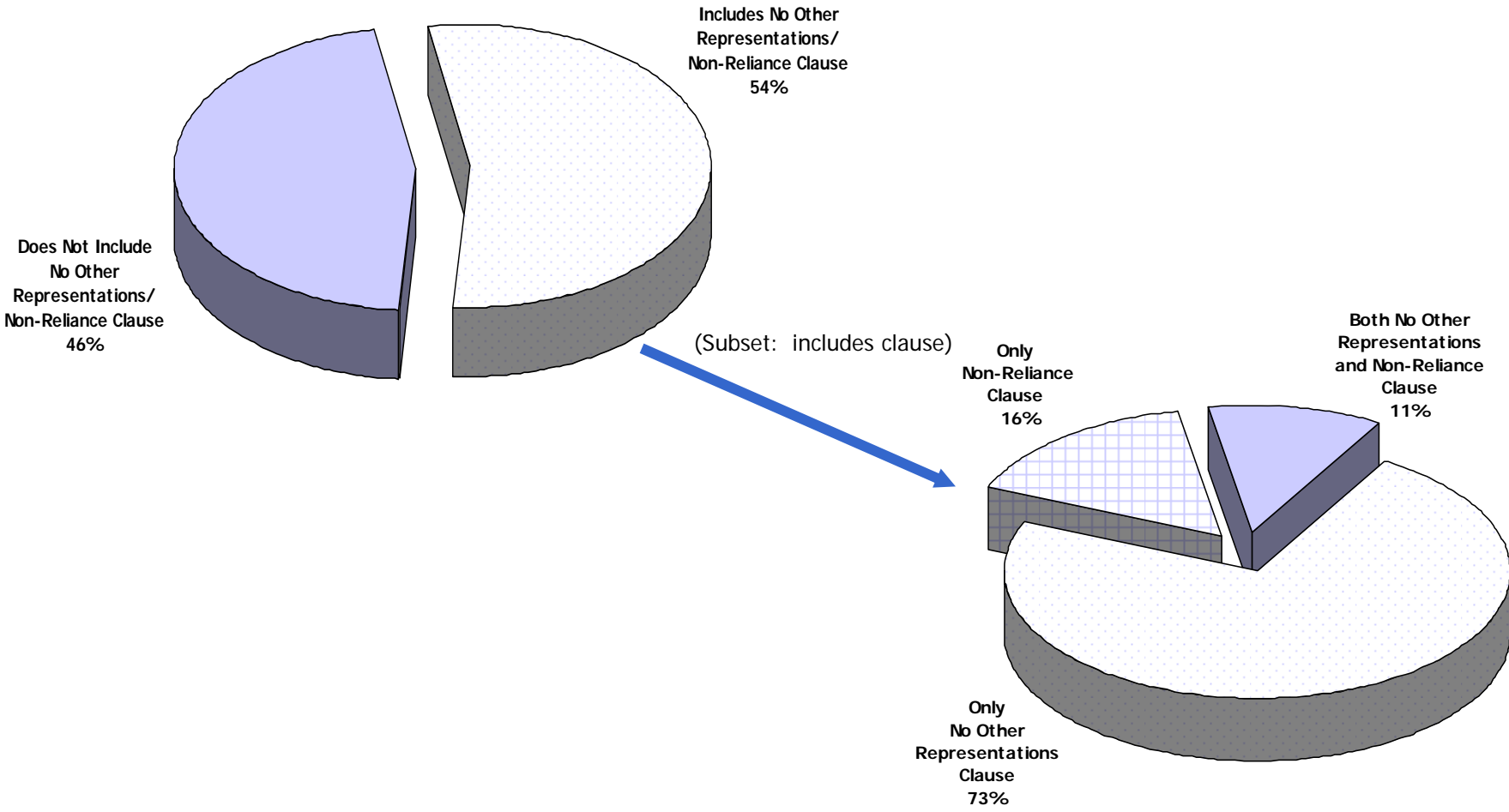

Remedies

Specific Performance

("Entitled" to Specific Performance)

"Specific Performance. [Buyer/Target/the Parties] agree that money damages would not be a sufficient remedy for any breach of this Agreement [by Parent/Target]. It is hereby agreed that, prior to termination of this Agreement pursuant to Section 8.1, [Buyer/Target/the Parties] **shall be entitled to** specific performance and injunctive relief as a remedy for any such breach and to enforce compliance with the covenants of [Buyer/Target/the Parties] set forth in [Article V]."

("May Seek" Specific Performance)

"Specific Performance. [Buyer/Target/the Parties] agree that money damages would not be a sufficient remedy for any breach of this Agreement [by Parent/Target]. It is hereby agreed that, prior to termination of this Agreement pursuant to Section 8.1, [Buyer/Target/the Parties] shall be entitled **to seek** specific performance and injunctive relief as a remedy for any such breach and to enforce compliance with the covenants of [Buyer/Target/the Parties] set forth in [Article V]."

Specific Performance

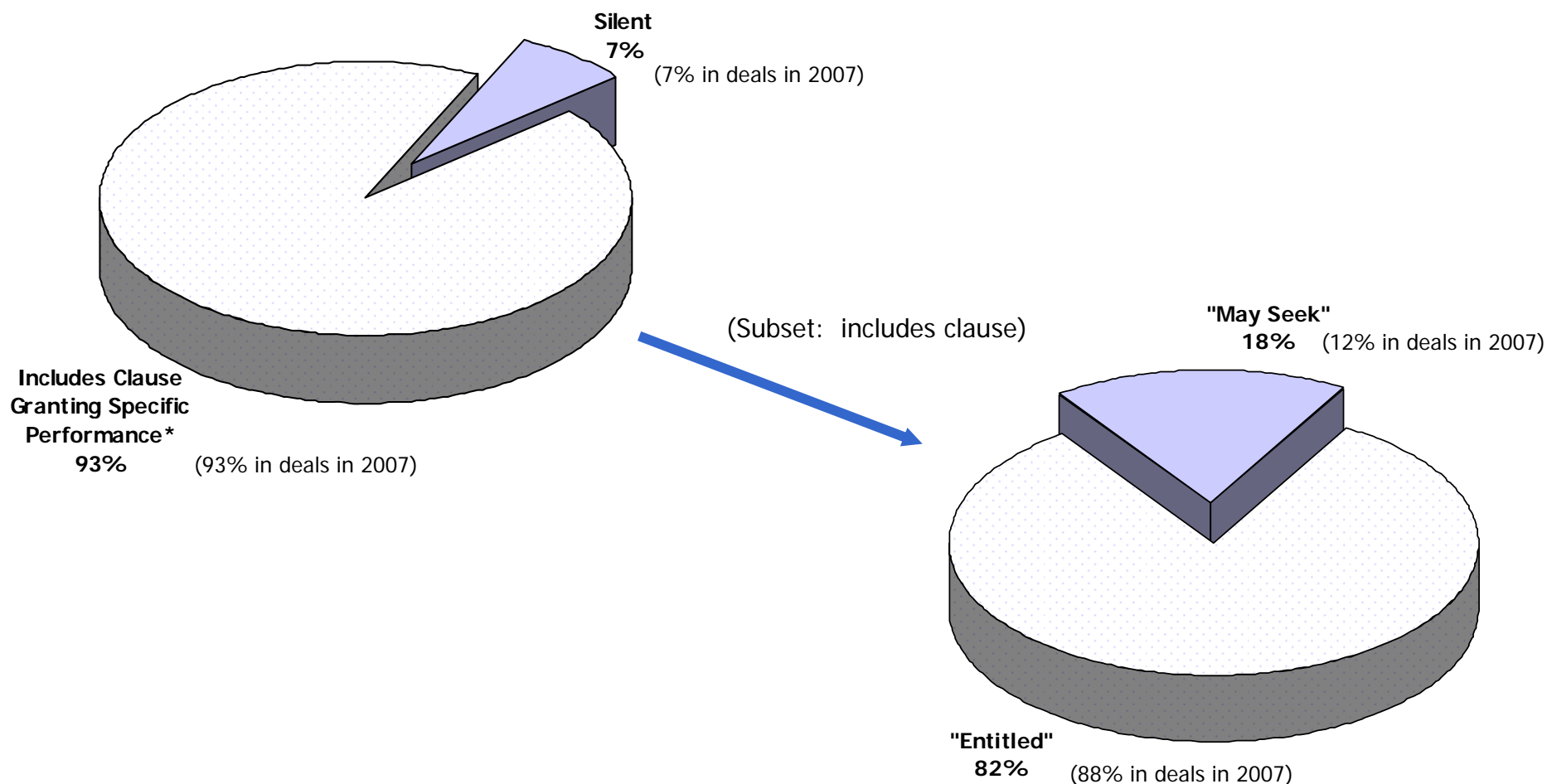

* Includes provisions in which the ability to obtain specific performance was provided for some covenants but was specifically disclaimed for other covenants (e.g., the obligation to close where financing for the acquisition is sought by the buyer).

Specific Performance (In Favor of Whom?*)

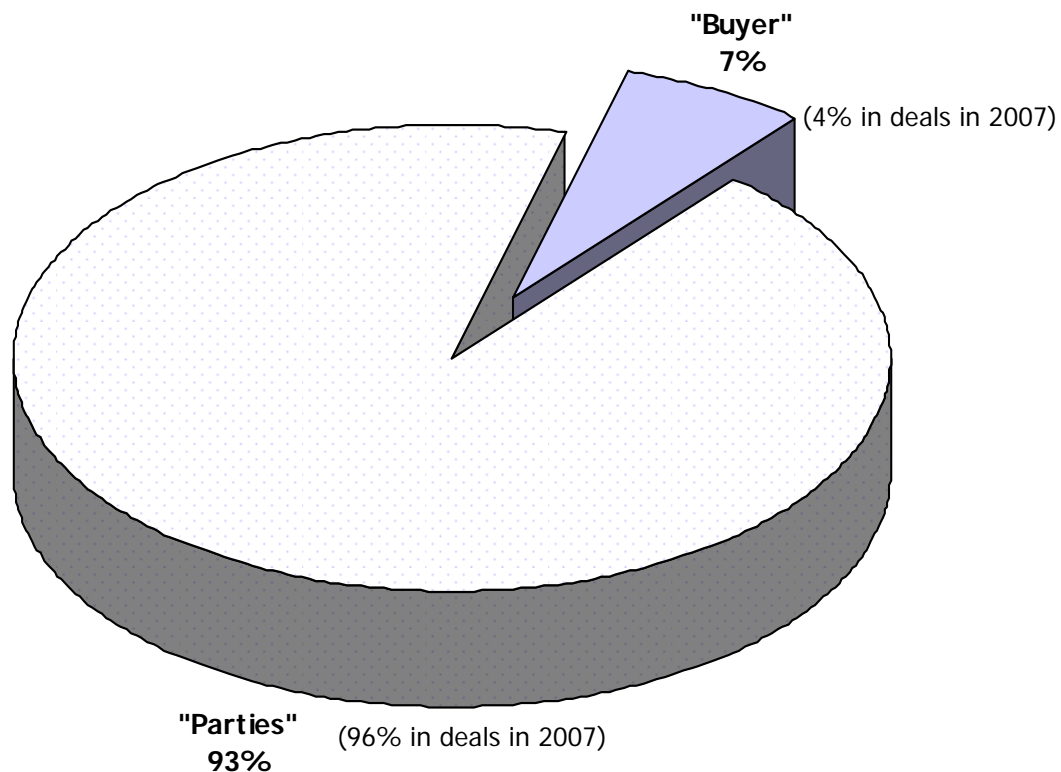

* None of the transactions in 2008 having an express provision providing for the remedy of specific performance granted that right *exclusively* to the target. A number of transactions granting the right to the buyer specifically provided that the target was not entitled to specific performance. Two transactions in 2008 granting that remedy exclusively to the buyer did provide a limited right to the target to obtain specific performance for the breach by the buyer of confidentiality obligations.

Specific Performance (Waiver of Bond)

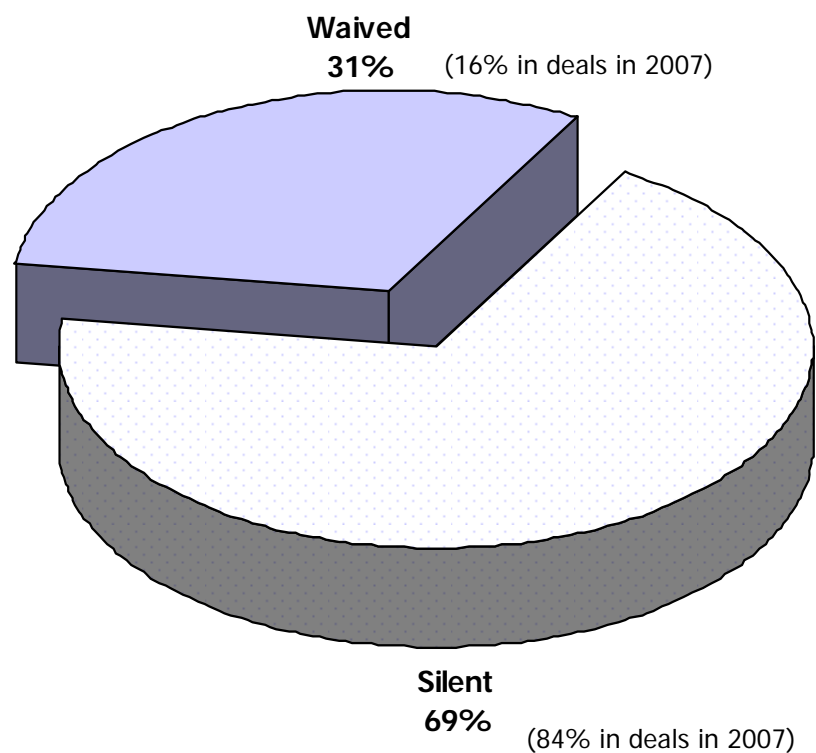

Effect of Termination Survival of Breaches

“Effect of Termination and Abandonment. In the event of termination of this Agreement and the abandonment of the Merger pursuant to this Article VIII, this Agreement shall become void and of no effect with no liability to any Person on the part of any party hereto (or their respective officers, directors, stockholders, Affiliates or Representatives); provided, however, and notwithstanding anything in the foregoing to the contrary, (a) the provisions set forth in Section 6.3 (Confidentiality Agreement), this Section 8.2, Section 8.3 (Termination Fees; Expenses) and Article IX shall remain in full force and effect and survive any termination of this Agreement, and (b) **no such termination shall relieve any party hereto of any liability or damages to the other party hereto resulting from any [willful or intentional material] breach of this Agreement.**”

Effect of Termination Survival of Breaches Representations and Warranties

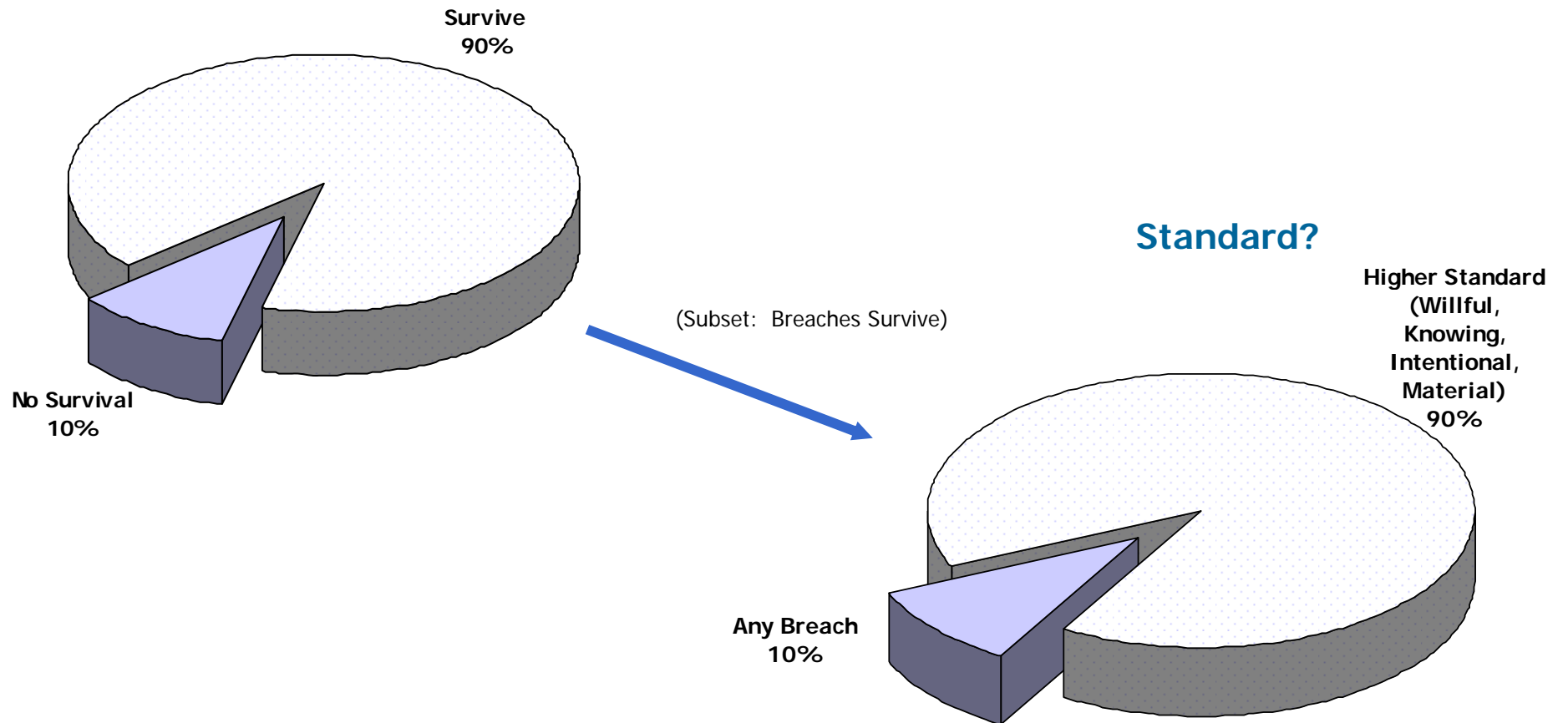

Effect of Termination Survival of Breaches Covenants

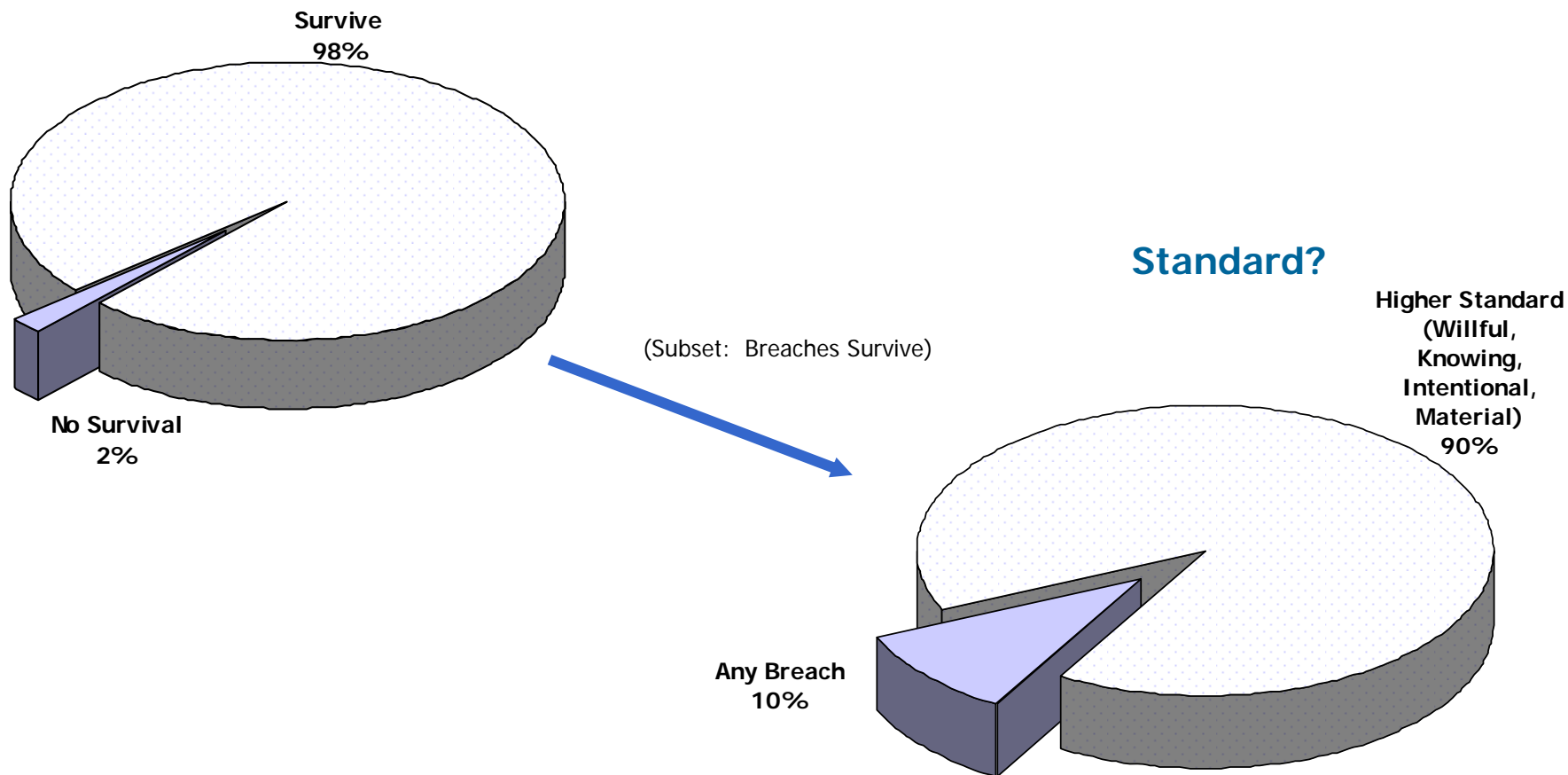

“Willful, Knowing, Intentional” Defined?

“**Willful and Material Breach** means a material breach that is a consequence of an act undertaken by the breaching party with the actual knowledge that the taking of such act would, or would be reasonably expected to, cause a breach of this Agreement.”

“**Willful Breach.** There shall be deemed to be a “Willful Breach” by Parent of a representation or warranty made by Parent only if : (i) such representation or warranty is material to the Company and was materially inaccurate when made by Parent; (ii) the material inaccuracy in such representation or warranty has a material adverse effect on the ability of Parent to consummate the Merger; (iii) the material inaccuracy in such representation or warranty shall not have been cured in all material respects; and (iv) when such representation or warranty was made by Parent, Parent’s chief financial officer or treasurer had actual knowledge that such representation or warranty was materially inaccurate and specifically intended to defraud the Company. There shall be deemed to be a “Willful Breach” by Parent of a covenant or obligation of Parent only if: (i) such covenant or obligation is material to the Company; (ii) Parent shall have materially and willfully breached such covenant or obligation; (iii) the breach of such covenant or obligation has a material adverse effect on the ability of Parent to consummate the Merger; (iv) the breach of such covenant or obligation shall not have been cured in all material respects; and (v) Parent’s chief financial officer or treasurer had actual knowledge, at the time of Parent’s breach of such covenant or obligation, (A) that Parent was breaching such covenant or obligation and (B) of the consequences of such breach under the Agreement.”

“Willful, Knowing, Intentional” Defined?*

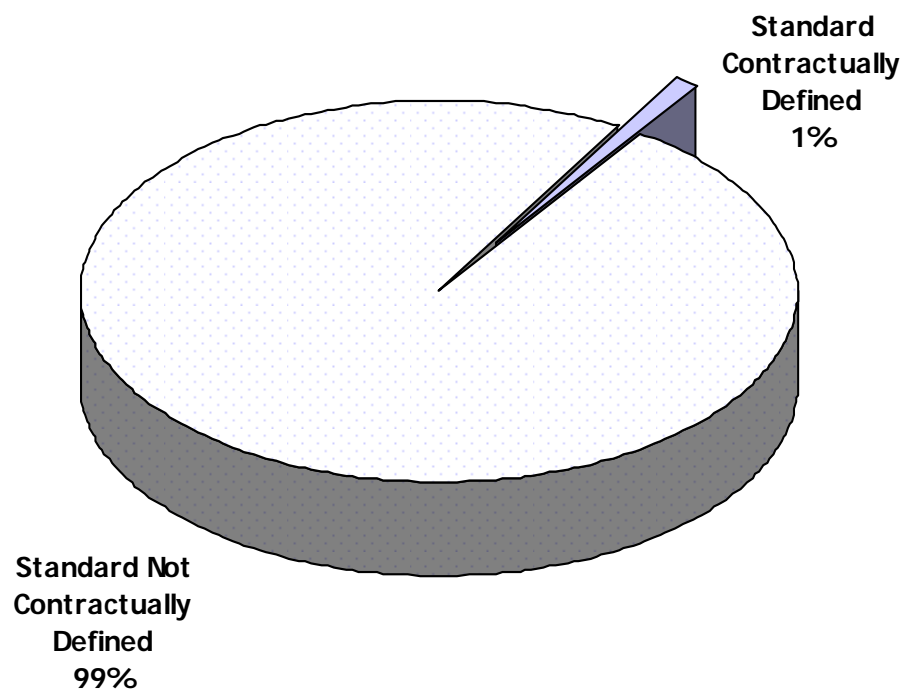

* “Willful, Knowing, Intentional” and similar language may be utilized in different contexts in an acquisition agreement. This data set reflects the frequency in which such language was contractually defined, regardless of the context.

Express Target Right to Pursue Damages on Behalf of Stockholders

“No Third Party Beneficiaries. Except for: (a) the right of the Indemnified Parties to enforce the provisions of Section 6.12 (Indemnification; Directors’ and Officers’ Insurance) only, and (b) *the right of the Company on behalf of its stockholders to pursue damages [(including claims for damages based on loss of the economic benefits of the transaction to the Company’s stockholders)] in the event of Parent’s or Merger Sub’s breach of this Agreement (whether or not the Agreement has been terminated pursuant to Article VIII), which right is hereby expressly acknowledged and agreed by Parent and Merger Sub;* (1) Parent and the Company hereby agree that their respective representations, warranties and covenants set forth herein are solely for the benefit of the other party hereto, in accordance with and subject to the terms of this Agreement, and (2) this Agreement is not intended to, and does not, confer upon any Person other than the parties hereto any rights or remedies hereunder, including the right to rely upon the representations and warranties set forth herein. *[The third-party beneficiary rights referenced in clause (b) of the preceding sentence may be exercised only by the Company (on behalf of its stockholders as their agent) through actions expressly approved by the Company’s Board of Directors, and no stockholders of the Company whether purporting to act in its capacity as a shareholder or purporting to assert any right (derivatively or otherwise) on behalf of the Company, shall have any right or ability to exercise or cause the exercise of any such right.]*”

Express Target Right to Pursue Damages on Behalf of Stockholders*

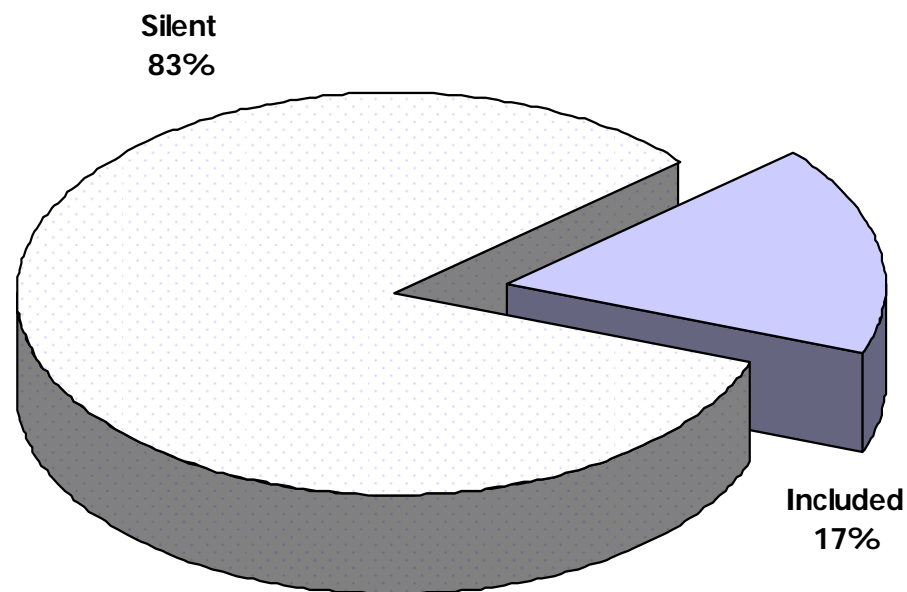

* The data set excludes transactions involving solely stock as consideration, none of which included express language providing the target the right to pursue damages on behalf of the target's stockholders.

Termination Fee Payable by Buyer (For General Breach)

“(c) Reverse Termination Fee.”

(i) In the event this Agreement is terminated:

(A) by the Company pursuant to Section 8.1(d)(i) [Buyer Breach of Representations, Warranties or Covenants] (if at the time of such termination there is no state of facts or circumstances (other than a state of facts or circumstances caused by or arising out of a breach of Parent’s and Merger Sub’s representations, warranties, covenants or other agreements set forth in this Agreement) that would reasonably be expected to cause the conditions set forth in Section 7.1 and Section 7.2 not to be satisfied on or prior to the Termination Date) . . .

. . . then in the case of a termination under the circumstances described in clause (A) above, Parent shall pay \$50,000,000 (the “Reverse Termination Fee”) to, or as directed by, the Company, as promptly as reasonably practicable (and, in any event, within two business days following such termination) by wire transfer of same day funds.

(ii) The Company’s right to receive payment of the Reverse Termination Fee from Parent shall be the sole and exclusive remedy of the Company and its affiliates against Parent, Merger Sub or any of their respective former, current or future directors, officers, employees, agent, stockholders, representatives, affiliates or assignees or any former, current or future director, officer, employee, agent, general or limited partner, manager, member, stockholder, representative, affiliate or assignee of any of the foregoing (collectively, the “Related Persons”) for any loss or damage suffered as a result of the failure of the Merger to be consummated or for a breach or failure to perform under this Agreement or otherwise.”

Termination Fee Payable by Buyer (For General Breach)*

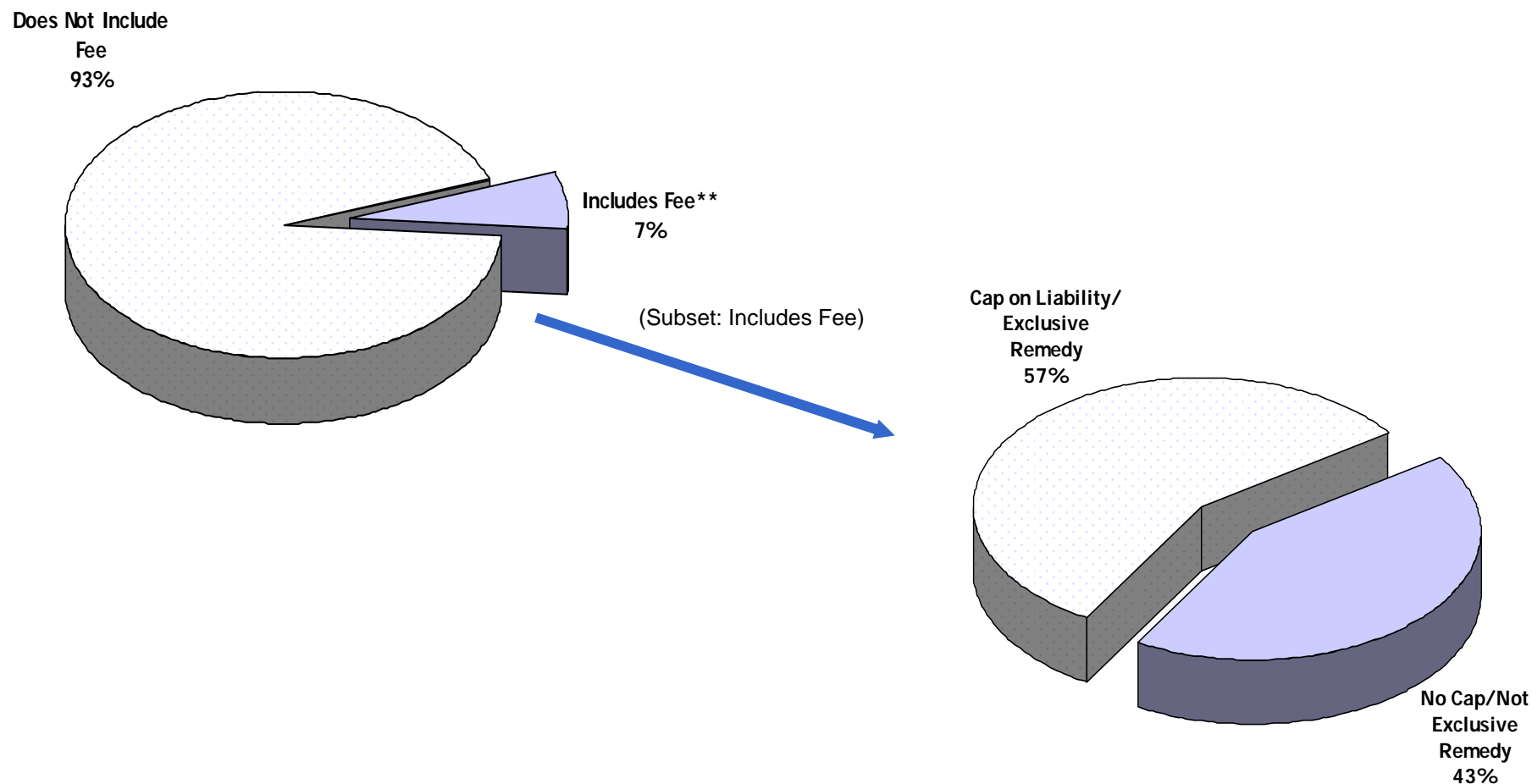

* Represents transactions where a termination fee is payable by the buyer for general breaches of representations, warranties and covenants.

** Does not include mere expense reimbursement. Two transactions contained a reverse termination fee provision requiring buyer to reimburse expenses in the event the transaction was terminated for a buyer's general breach. One transaction contained additional requirements for the payment of the reverse termination fee to be triggered (e.g., the closing of a separate transaction).

Termination Fee Payable by Buyer (For Failure to Obtain Financing)

“(e) The Buyer agrees that, if the Company shall terminate this Agreement pursuant to (i) Section 8.01(e) [Buyer Breach]; (ii) Section 8.01(b) [Outside Date]; and, at the time of such termination, the conditions set forth in Section 7.01 and Sections 7.02(a), (b), (d) and (e) have been satisfied; or (iii) Section 8.01(i) [conditions satisfied and Merger not consummated], then the Buyer shall pay to the Company a fee of \$50,000,000 (the “Parent Termination Fee”) in immediately available funds no later than two business days after such termination by the Company.”

“The parties agree that the payment of the Parent Termination Fee shall be the sole and exclusive remedy available to the Company with respect to this Agreement and the transactions in the event of termination of this Agreement as provided in this Section 8.02(e) and, upon payment of the Parent Termination Fee, Parent shall have no further liability to the Company hereunder, [provided, that the foregoing limitation . . . shall not apply in the event of any liabilities or damages incurred or suffered by the Company in the case of a breach of this Agreement involving fraud or willful or intentional misconduct.]”

Termination Fee Payable by Buyer (For Failure to Obtain Financing)*

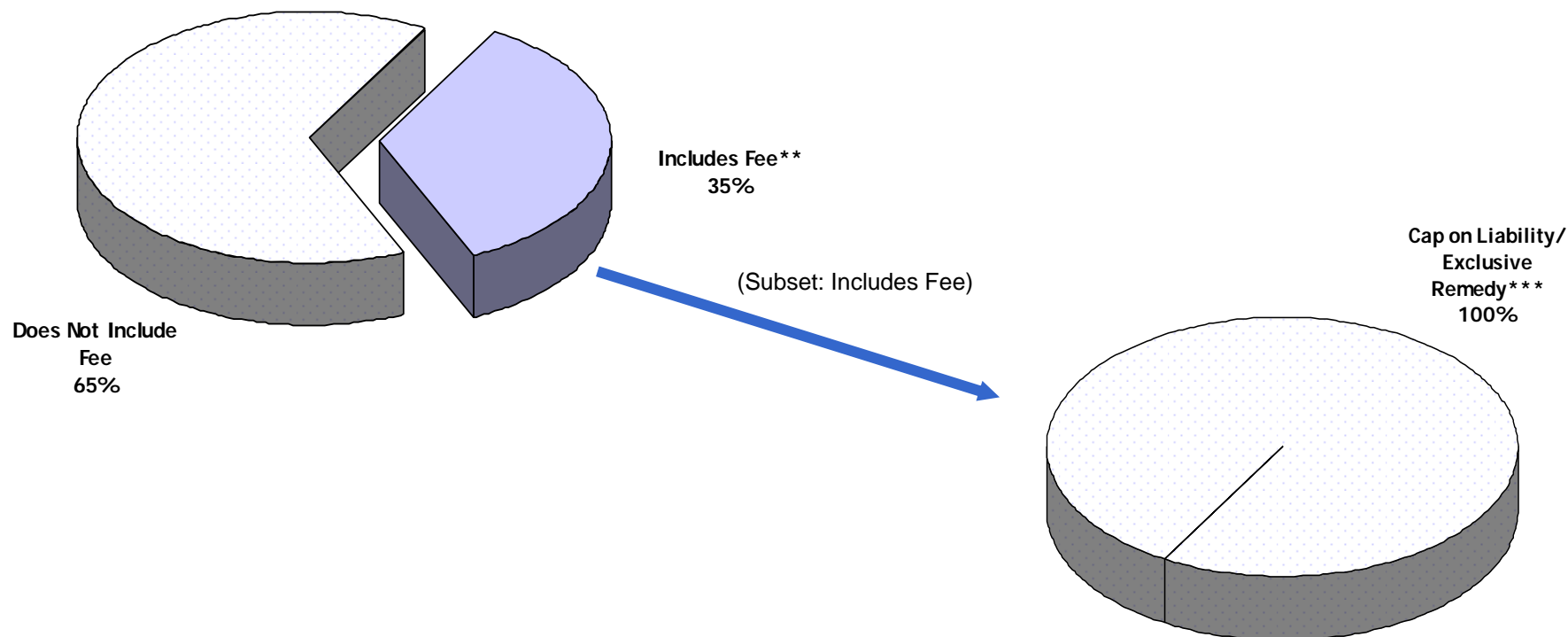

* Subset of transactions in which cash was included as consideration and where the buyer contemplated obtaining financing for the acquisition. For purposes of the data set, transactions which included (i) representations by the buyer regarding commitment letters (or similar obligations) with respect to obtaining financing, or (ii) covenants on behalf of the buyer to use specified efforts to obtain referenced financing prior to closing were deemed transactions where the buyer contemplated obtaining financing for the acquisition. Transactions that contained buyer representations generally providing that buyer would have “funds available at closing” were not deemed transactions where the buyer contemplated obtaining financing for the acquisition. The data set excludes transactions that contained a financing condition in favor of buyer with no fee payable thereunder.

** Does not include mere expense reimbursement.

*** Two of the eight transactions specifically exclude fraud and willful or intentional breaches from the cap.

Two-Step Cash Transactions (Tender Offer Deals)

Structure of Cash Deals*

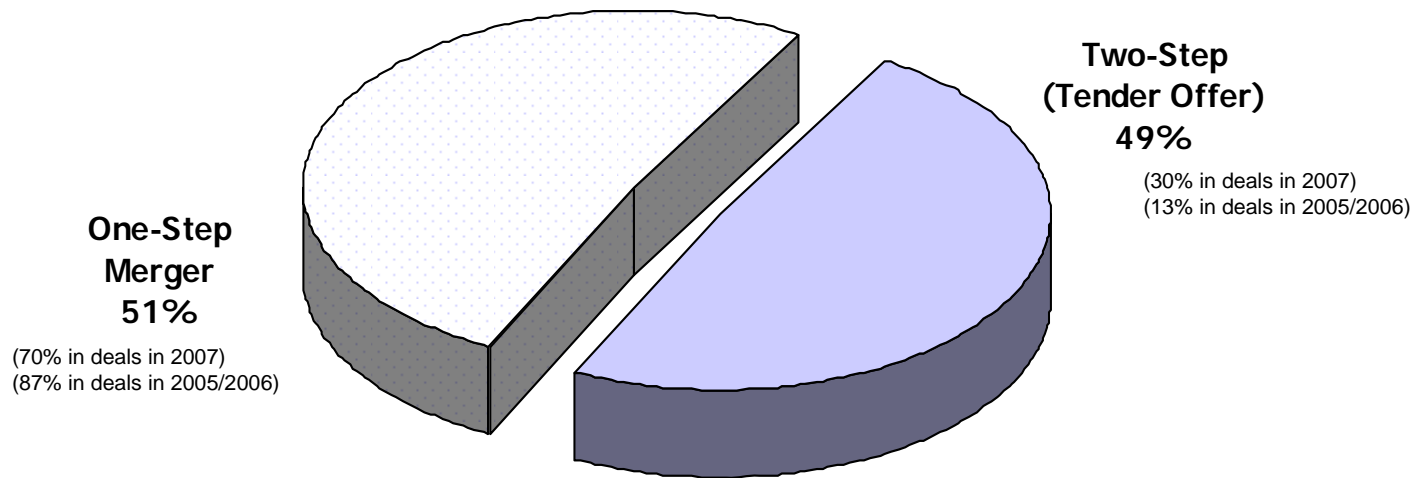

* Of the transactions in 2008 involving cash as consideration where the buyer contemplated obtaining financing for the acquisition, approximately 64% were structured as a one-step merger and approximately 36% were structured as a two-step merger (tender offer).

Cash Tender Offer Minimum Condition

“Notwithstanding any other provisions of the Offer, Merger Sub shall not be required to accept for payment or, . . . pay for any tendered shares of Company Common Stock . . . if (i) there shall not be validly tendered (and not withdrawn) prior to the Expiration Date for the Offer that number of shares of Company Common Stock which, when added to any shares of Company Common Stock owned by Parent or any of its Subsidiaries, represents at least a majority of the total number of outstanding shares of Company Common Stock **[on a fully diluted basis] [(assuming conversion or exercise of all derivative securities regardless of the conversion or exercise price, the vesting schedule or other terms and conditions thereof)] [excluding shares tendered by guaranteed delivery for which the underlying shares have not been received]** on the Expiration Date (the “Minimum Condition”).”

Cash Tender Offer Minimum Condition Fully Diluted Shares or Outstanding Shares

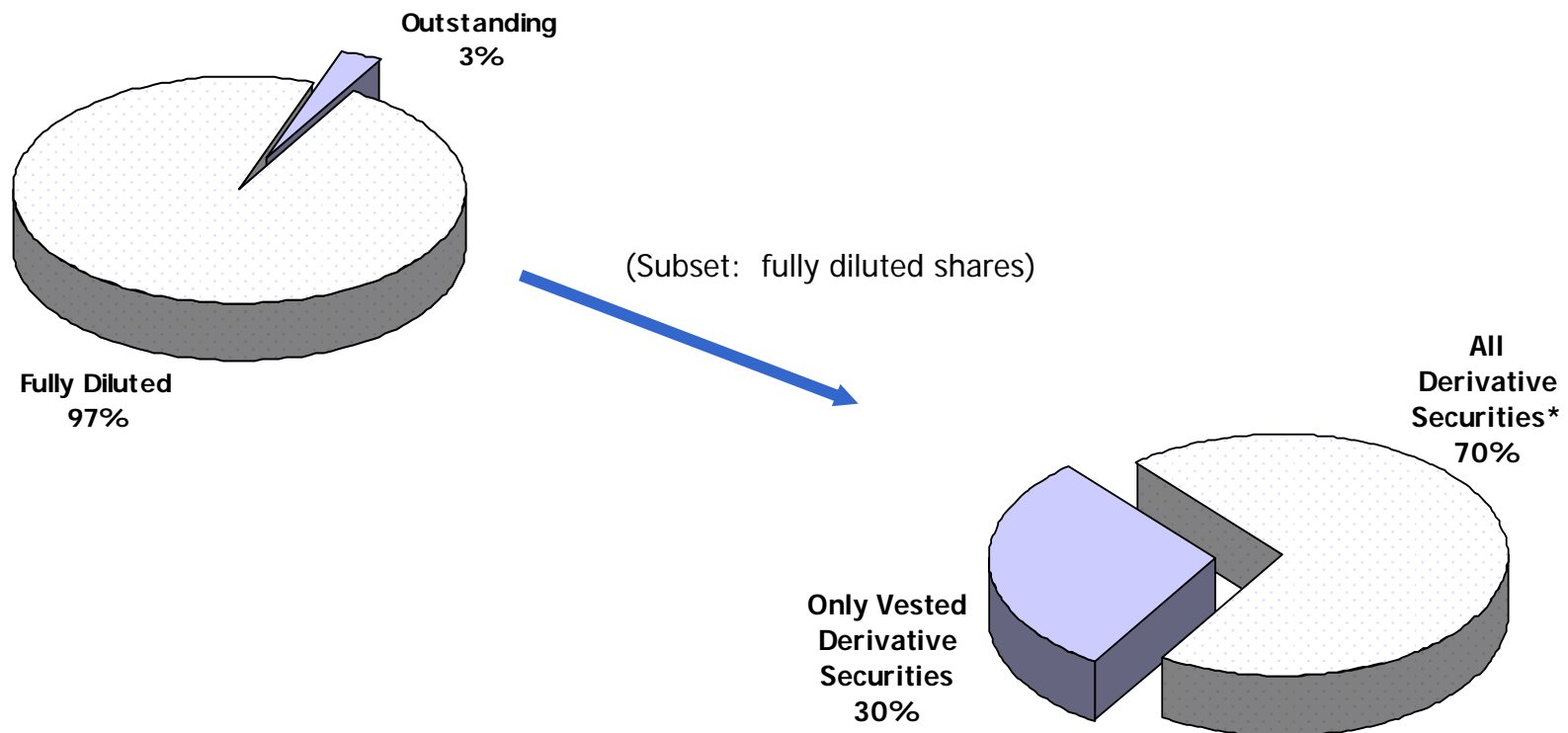

* Some transactions specifically carved out certain derivative securities from the minimum condition.

Cash Tender Offer Minimum Condition Guaranteed Deliveries Not Received Excluded From Minimum Condition?

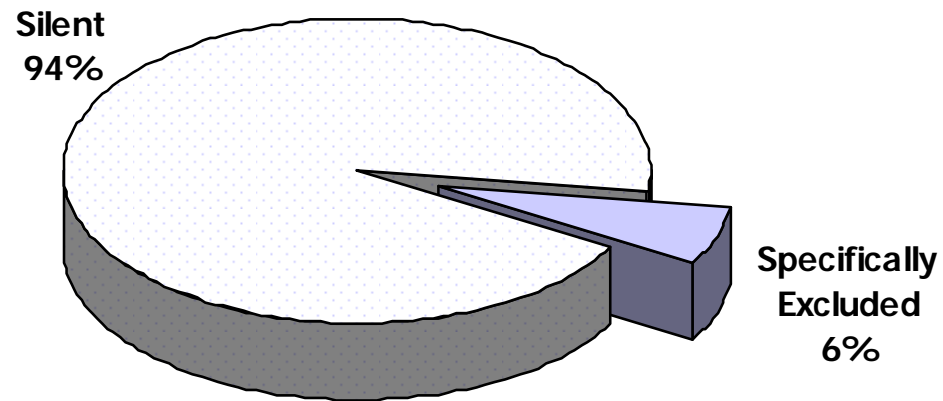

Top-Up Option

“Top-Up Option.

(a) The Target hereby grants to the Buyer and Acquisition Sub an irrevocable option (the “Top-Up Option”) to purchase that number of Shares (the “Top-Up Option Shares”) equal to the lowest number of Shares that, when added to the number of Shares owned by the Buyer and/or Acquisition Sub at the time of exercise of the Top-Up Option, shall constitute one Share more than 90% of the Shares then outstanding (assuming the issuance of the Top-Up Option Shares) at a price per Share equal to the Offer Price; *provided, however*, that the Top-Up Option shall not be exercisable unless immediately after such exercise the Buyer and/or Acquisition Sub would own more than 90% of the Shares then outstanding.

(b) The Buyer or Acquisition Sub may exercise the Top-Up Option, in whole but not in part, at any time after the occurrence of a Top-Up Exercise Event and prior to the occurrence of a Top-Up Termination Event.

(c) For the purposes of this Agreement, a “Top-Up Exercise Event” shall occur upon Acquisition Sub’s acceptance for payment pursuant to the Offer of Shares constituting less than 90% of the Shares then outstanding. Each of the following shall be a “Top-Up Termination Event”: (i) the Effective Time; and (ii) the termination of this Agreement pursuant to its terms.”

Top-Up Option

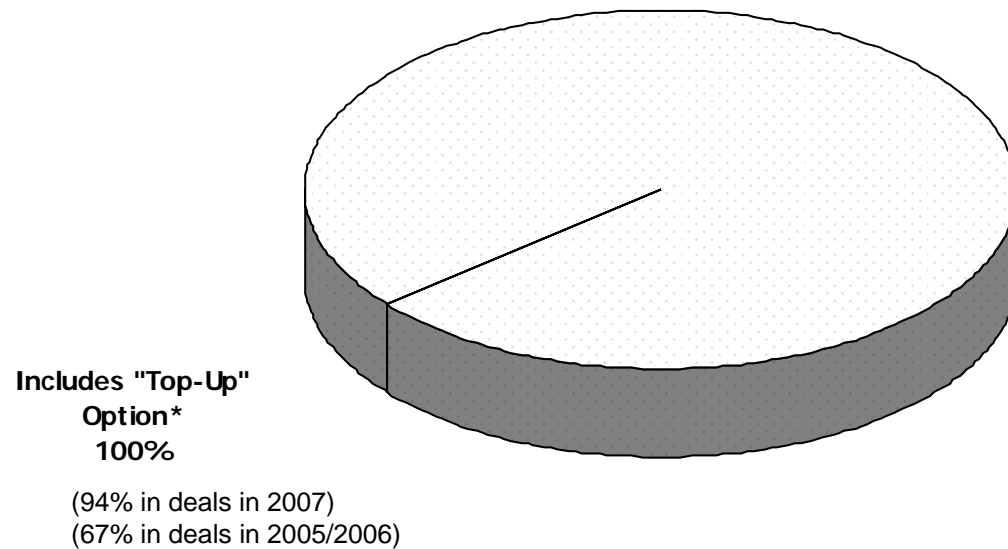

* Excludes one transaction in 2008 involving a controlling stockholder.

Top-Up Option Threshold Trigger

“Top-Up Option.

(a) The Target hereby grants to the Buyer and Acquisition Sub an irrevocable option (the “Top-Up Option”) to purchase that number of Shares (the “Top-Up Option Shares”) equal to the lowest number of Shares that, when added to the number of Shares owned by the Buyer and/or Acquisition Sub at the time of exercise of the Top-Up Option, shall constitute one Share more than 90% of the Shares then outstanding (assuming the issuance of the Top-Up Option Shares) at a price per Share equal to the Offer Price; *provided, however*, that the Top-Up Option shall not be exercisable unless immediately after such exercise the Buyer and/or Acquisition Sub would own more than 90% of the Shares then outstanding.

(b) The Buyer or Acquisition Sub may exercise the Top-Up Option, in whole but not in part, at any time after the occurrence of a Top-Up Exercise Event and prior to the occurrence of a Top-Up Termination Event.

(c) For the purposes of this Agreement, a “Top-Up Exercise Event” shall occur upon Acquisition Sub’s acceptance for payment pursuant to the Offer of Shares constituting **[80]% or more** of the Shares then outstanding. Each of the following shall be a “Top-Up Termination Event”: (i) the Effective Time; and (ii) the termination of this Agreement pursuant to its terms.”

Top-Up Option Threshold Trigger

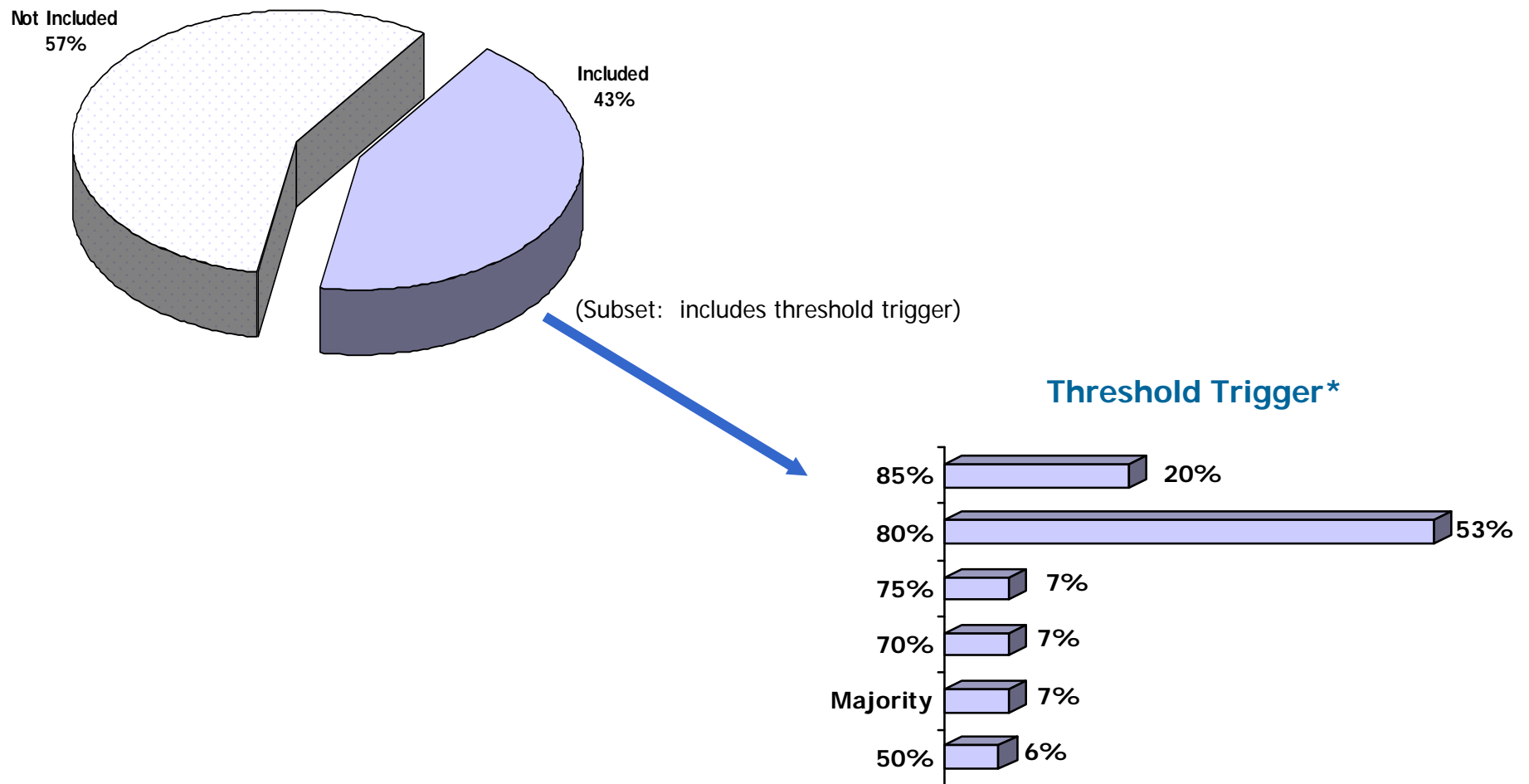

* Represents agreements containing a top-up option that conditioned the exercisability by the buyer of the top-up option on the tender of a specified threshold percentage of outstanding shares.

Conditions Regarding Trading Suspension; Banking Moratorium; War/Terrorism; Limitation on Extension of Credit

“ANNEX A”

CONDITIONS TO THE OFFER

...Acquisition Sub shall not be required to accept for payment ...any tendered Target Shares, if... at any time on or after the execution and delivery of the Agreement and prior to the time of acceptance for payment for any such Target Shares, any of the following events shall have occurred:

(c) ... (i) **any general suspension of trading** in, or limitation on prices for, securities on the New York Stock Exchange or on the Nasdaq, for a period in excess of twenty four hours; (ii) a declaration of a **banking moratorium** or any suspension of payments in respect of banks in the United States (whether or not mandatory); (iii) a commencement of a **war, armed hostilities or other international or national calamity (including terrorist activity)** directly or indirectly involving the United States; (iv) **any limitation** (whether or not mandatory) by any United States governmental authority **on the extension of credit generally** by banks or other financial institutions.”

Conditions Regarding Trading Suspension; Banking Moratorium; War/Terrorism; Limitation on Extension of Credit

Banking Moratorium

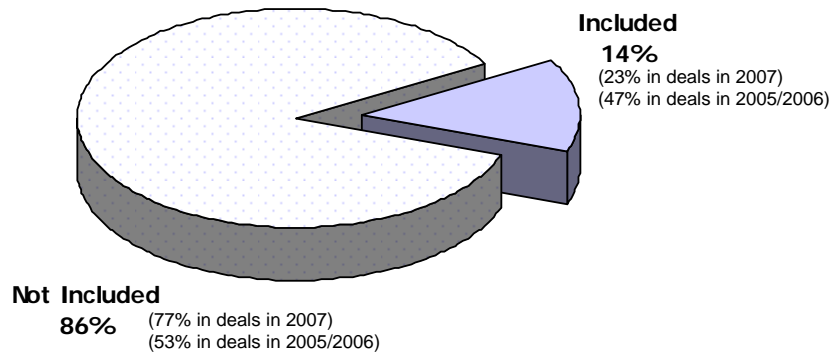

Limitation on Extension of Credit

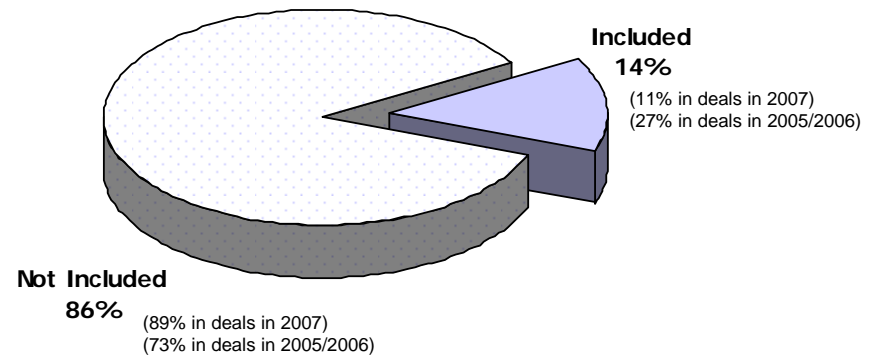

Trading Suspension

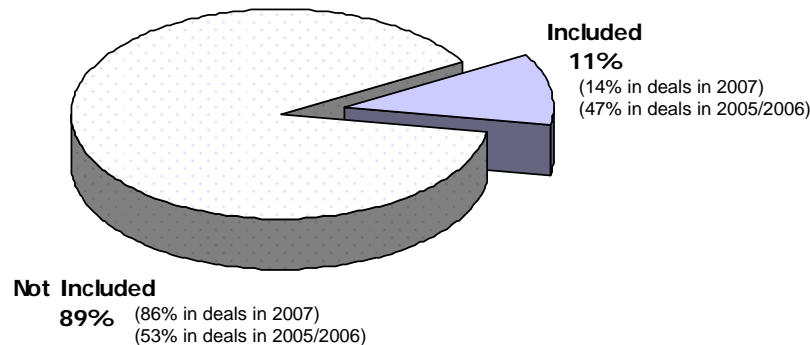

War/Terrorism

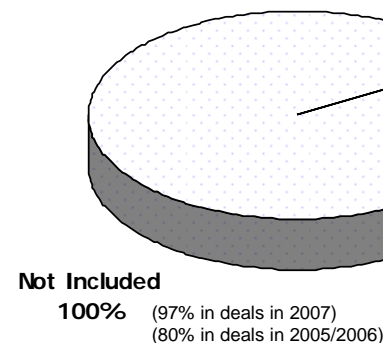



Mergers & Acquisitions Committee

“Where the World’s Leading Dealmakers Meet”

The Mergers & Acquisitions Committee was founded in the late 1980s and has over 3,700 members, including practitioners from 47 states, five Canadian provinces and more than 39 different countries on five continents. The Committee is home to the world’s leading merger and acquisition (M&A) attorneys and many other deal professionals such as investment bankers, accountants, and consultants. In addition, over ten percent of committee membership includes in-house counsel.

Market Trends Studies

Get state-of-the-art market metrics in negotiated acquisitions with the Committee’s benchmark studies covering not only U.S. but also Canadian and EU deals. The studies, produced by the Committee’s M&A Market Trends Subcommittee, have become **essential resources for deal lawyers, investment bankers, corporate dealmakers, PE investors,** and others interested in “what’s market” for critical legal deal points in M&A. The Committee regularly produces the Private Target Deal Points Study, the Strategic Buyer/Public Target Deal Points Study, the Private Equity Buyer/Public Target Deal Points Study, the Canadian Private Target Deal Points Study, and the Continental Europe Private Target Deal Points Study. The studies, as well as updates (and Update Alerts), are available free of charge to Committee members only.

Knowledge and Networking

The Committee meets regularly three times a year at the ABA Annual Meeting, Section Spring Meeting, and a Fall Committee Meeting.

All Committee **materials and resources** used in CLE programs on M&A-related topics presented both at ABA meetings and in other forums are accessible to all members via the Section’s **online Program Library**. These programs bring together panels of experienced M&A practitioners from law firms and corporate law departments, as well as those in academia and others outside the legal profession who are experts in their field.

<<< Join the Committee! >>>

Committee membership is **FREE** for Business Law Section members.

For immediate enrollment in the Committee or Section, log in at **www.ababusinesslaw.org**.